



**GAI-TRONICS® CORPORATION**  
A HUBBELL COMPANY

# Model XB001

## Weatherproof Long-Life Battery Enclosure

---

### Confidentiality Notice

This manual is provided solely as an operational, installation, and maintenance guide and contains sensitive business and technical information that is confidential and proprietary to GAI-Tronics. GAI-Tronics retains all intellectual property and other rights in or to the information contained herein, and such information may only be used in connection with the operation of your GAI-Tronics product or system. This manual may not be disclosed in any form, in whole or in part, directly or indirectly, to any third party.

### General Information

The Model XB001 Weatherproof Long-Life Battery Enclosure is intended for use with the Model 13352, 13362, or 13372 Addressable Amplified Speaker Assemblies, the Model CP190 or CB191 RF Call Boxes and/or the SPK200 Solar Panel Interface Kit. It includes the following components:

Qty	Description
1	Enclosure assembly
4	Screws, #10-32 × 1.125-inch
4	Washers
1	Wiring harness with weatherproof plug

#### **Recommended accessories:**

1	Model 230 Mounting Kit
1	Model 40201-008 Battery, 12V, 18Ah

# Installation

## Mounting the Enclosure

1. Remove the four screws from the front of the enclosure. Open the front cover to the left and pull straight out until the hinge pins separate from the rear section. Set the front door of the enclosure aside.
2. Secure the rear section of the external battery enclosure to the desired surface with screws or appropriate customer-provided fasteners. Each enclosure mounting hole is 0.280 inch in diameter allowing the use of 1/4-inch diameter screws. Refer to Figure 1. The enclosure can also be mounted to a Model 230 Pole Mounting Kit for pole or surface mounting. Four mounting screws are provided with the pole mounting kit.

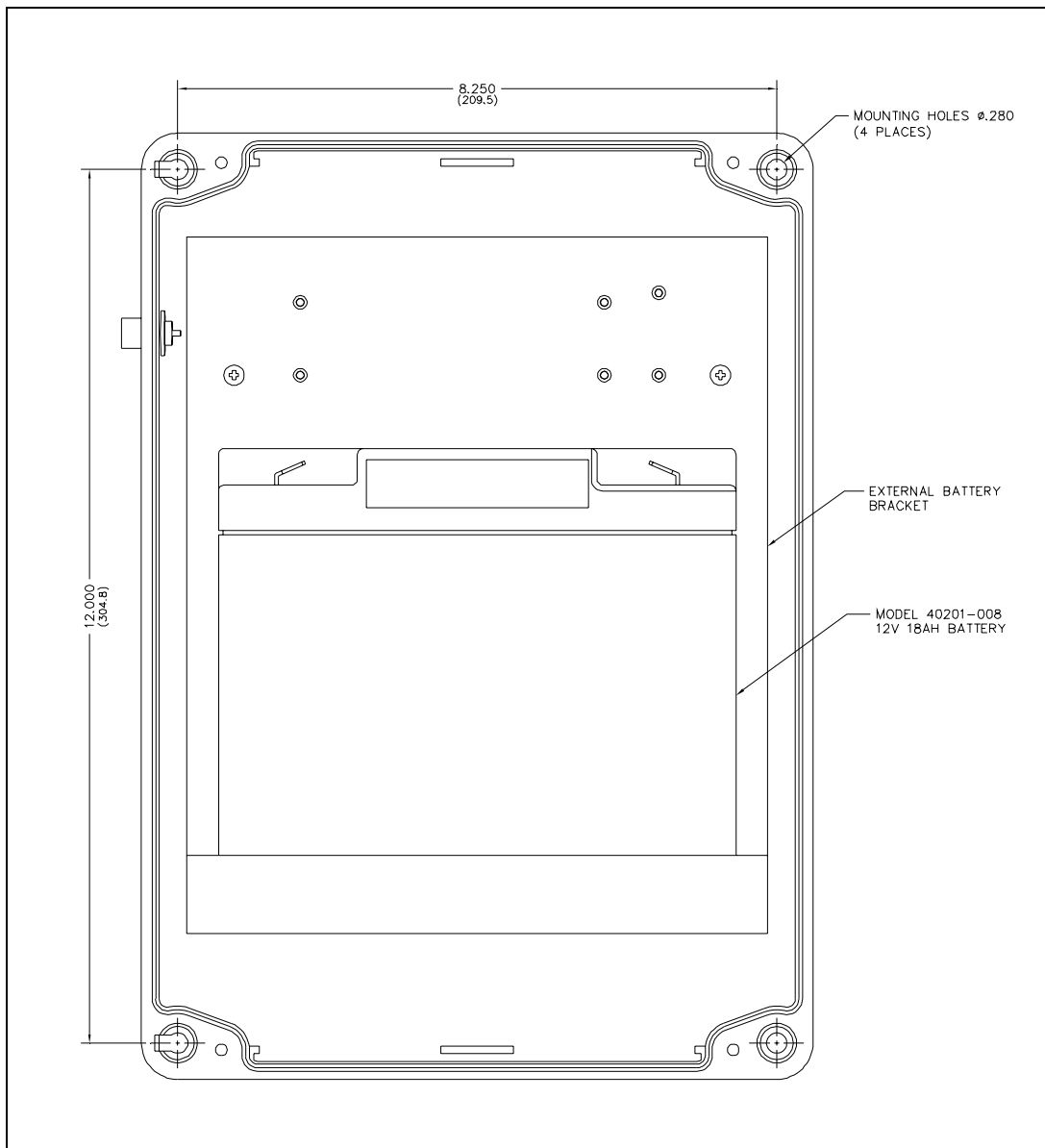

Figure 1. Rear half of the enclosure

3. Place the No. 40201-008 battery onto the mounting panel in the enclosure. Refer to Figure 2. The positive battery terminal should be on the right side when facing the enclosure.

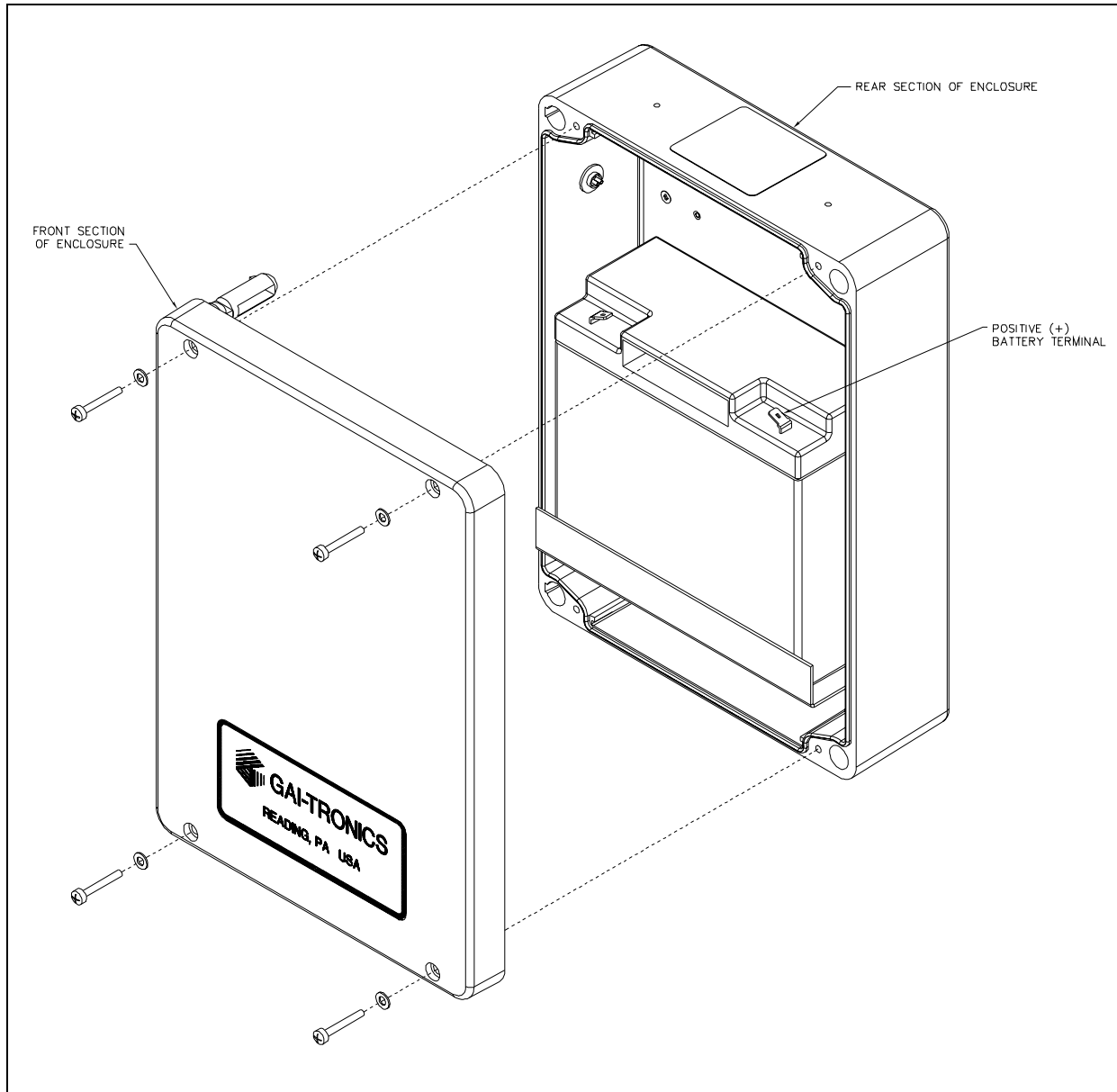

Figure 2. Exploded view of the external battery enclosure

4. Connect the wiring harness's quick-connect fastons to the battery terminals: **red to positive, black to negative**. Refer to Figure 3.
5. Return the door to the rear section by inserting the hinge pins and pushing into place, closing the door, and re-installing the four screws using 16 to 20 inch-pounds of torque.

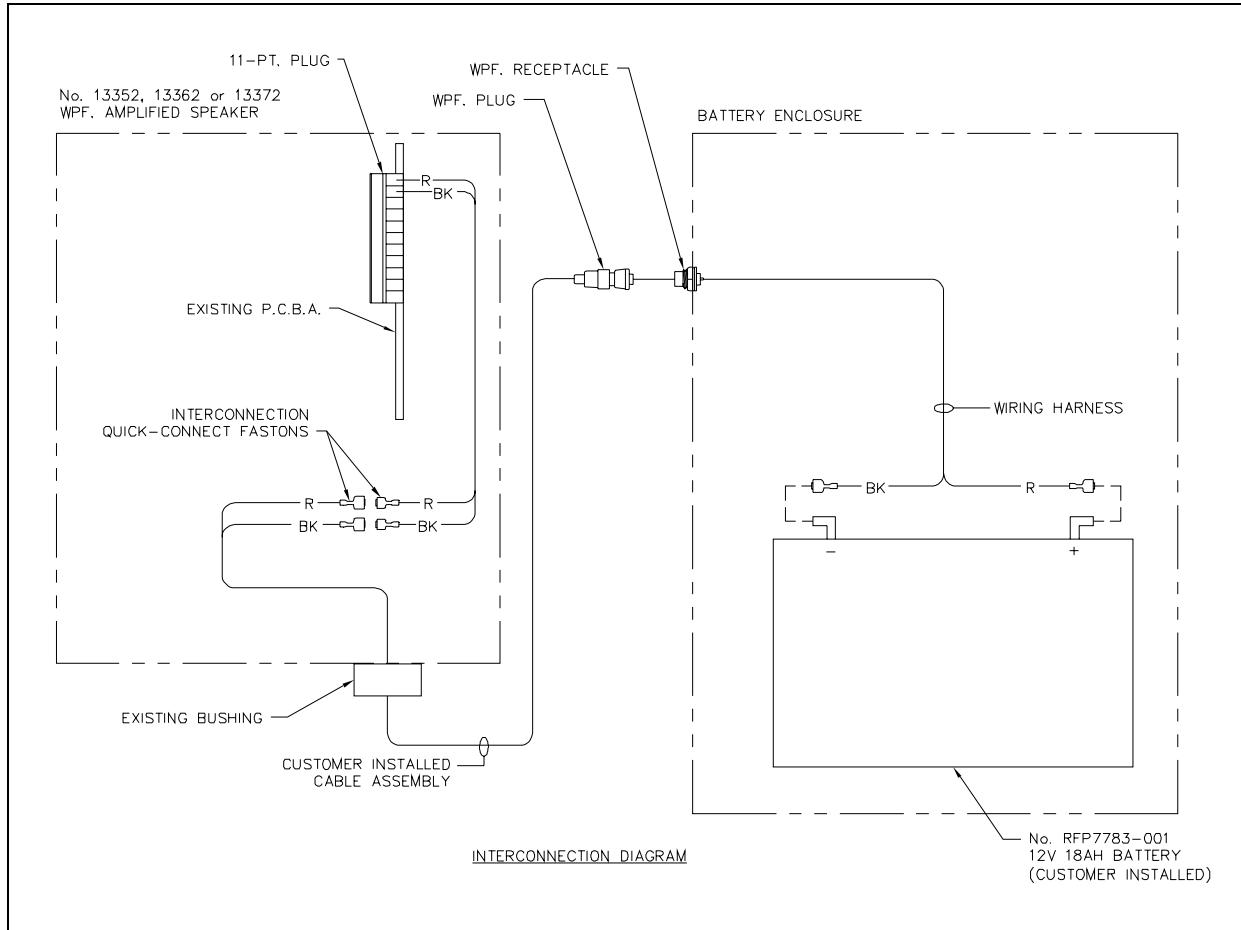

Figure 3. Interconnection Diagram

## Connecting to the Addressable Amplified Speaker

1. The Addressable Speaker is shipped with only two of the six screws securing the front section to the rear. Back out the two screws and separate the two sections, carefully setting aside the front section. Refer to GAI-Tronics Pub. 43004-030 for more detail.
2. Insert the lugged end of the (provided) weatherproof plug cable assembly through the existing cable bushing located on the bottom of the speaker housing's rear section. Wrap electrical tape around the cable where it enters the bushing until it has a minimum diameter of 0.25 inch, allowing approximately 10 inches of cable to remain inside the speaker housing. Tighten the bushing around the cable.
3. Connect the 3/16-inch male quick-connect fastons from the weatherproof plug cable assembly to the existing 3/16-inch fastons already attached to the speaker's 11-point terminal strip plug. It is extremely important to follow the color code noted in Figure 3. **Failure to match red to red and black to black could result in damaged circuitry.**
4. Mount the rear section of the enclosure within two feet of the battery box and attach the speaker front as described in Pub. 43004-030.
5. Insert the speaker cable plug into the receptacle located on the upper left side of the battery enclosure.

## Connecting to the RF Call Box

1. Install the customer-provided weather-tight cable bushing in the bottom (right side) of the Call Box rear section.
2. Remove the lugs from the weatherproof plug assembly, strip the wire insulation 1/8 inch, and insert the cable through the previously installed cable bushing. Allow enough cable inside the enclosure to connect the power input terminal strip (P5), located on the PCBA, with the door open. Secure the red and black wires as noted in Figure 4 below:

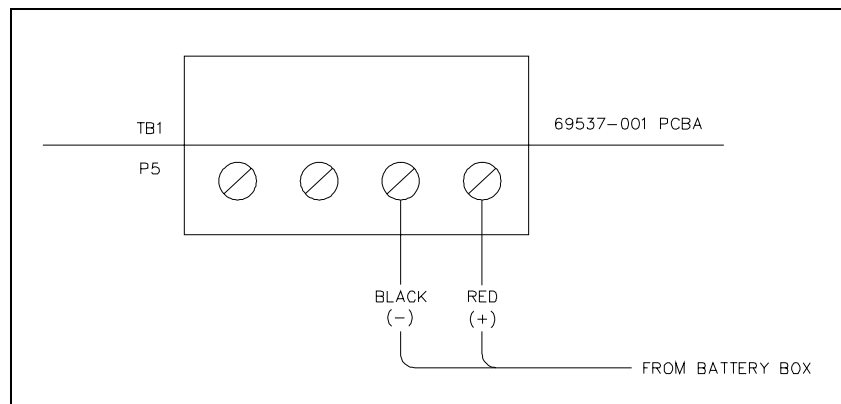

Figure 4.

3. Close the Call Box door and tighten the screws using 16 to 20 inch-pounds of torque.
4. Mount the External Battery enclosure close enough to the RF Call Box mounting location to allow the plug cable assembly to be connected to the receptacle located on its upper left side.