



GAI-TRONICS® CORPORATION
A HUBBELL COMPANY

Model 476-002

Centra-Page Flush-Mount Station

Confidentiality Notice

This manual is provided solely as an operational, installation, and maintenance guide and contains sensitive business and technical information that is confidential and proprietary to GAI-Tronics. GAI-Tronics retains all intellectual property and other rights in or to the information contained herein, and such information may only be used in connection with the operation of your GAI-Tronics product or system. This manual may not be disclosed in any form, in whole or in part, directly or indirectly, to any third party.

Introduction

GAI-Tronics Centra-Page systems provide dependable paging and party line communications for rugged and hazardous industrial facilities. Centra-Page systems feature centrally located electronics that provide environmental protection and unitized amplification for easy maintenance. Standard Centra-Page cabinets can support up to 30 handset stations and, in most cases, up to 60 paging speakers. Alarms and telephone interfacing can also be added to Centra-Page systems.

The Model 476-002 Flush-Mount Station is used for paging and party line communications. **When installed in accordance with a control drawing 72979, the station provides intrinsically-safe operation in Class I, Div. 1, Groups C and D hazardous areas.** The station is equipped with a push-to-page handset and party line selector.

General Information

The Model 476-002 Flush-Mount Station is enclosed in a metallic housing with a front panel measuring 6 H × 3.5 W inches. See Figure 1 for the dimensions of the wall cutout needed for flush mounting the station.

Although there is no absolute limit on the number of stations in simultaneous use on a given intercom path (party line 1 or 2) for a conference-type call, the effectiveness of the sidetone rejection circuit diminishes and overall performance begins to diminish after four or more stations are connected together. Therefore, it is recommended that conference-call party line conversations be limited to four simultaneous users.

The Model 476-002 Station, like other Centra-Page stations, operates in conjunction with a plug-in Line Card PCBA housed in the central cabinet card rack assembly. The line cards are sold separately. The card contains the handset dc power source, dual-switching relays, and a 16-watt speaker amplifier with 8-ohm and 70-volt line outputs.

If installing this station as an add-on, please consult the following chart to ensure proper power is supplied.

Power Supply Current Requirements in Amps

Mode	10 Cards	20 Cards	30 Cards
Standby	0.8	1.5	2.3
Page (Full load)	5.7	11.4	17.1
Alarm (Typical)	3.8	7.5	11.3
Alarm (Max. Level)	12.5	25.0	37.5

NOTES:

1. Ratings at 27.0 V dc at central cabinet. Add 8% for page and alarm at 28.8 V dc.
2. Full load is defined as 15-watt load on all cards with levels as adjusted at factory; 2-watt alarm output.
3. Typical load is defined as 7.5-watt load (such as 16-ohm loudspeaker connected to 8-ohm output).
4. Maximum level is defined as 15-watt loads and level control adjusted for 15-watt alarm level on all cards.
5. Ratings for alarm based on continuous tones. Pulse tone reduces current to about 60%.

Installation

Mounting

Please refer to Figure 1 and Figure 2 for mounting details. The station has four mounting holes on the front panel, and is supplied with an opening for cable. Figure 1 shows the required dimensions for the wall cutout, and Figure 2 shows how to fit the flush-mount station into the cutout. When mounting the station, use caution to avoid damaging the components inside.

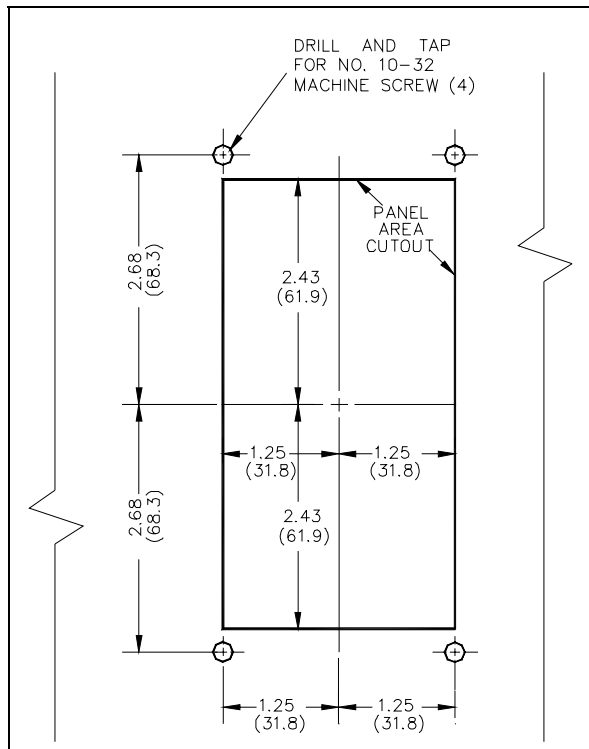

Figure 1. Cutout Dimensions

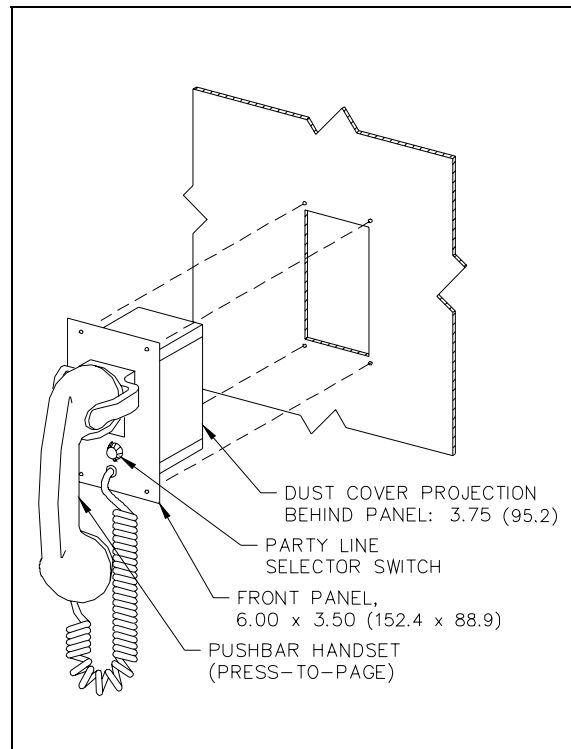

Figure 2. Mounting of Model 476-002 Station

Wiring

The configuration of the cable coming into the Model 476-002 depends on the chosen wiring method. For additional information, refer to Pub. 42004-356, Centra-Page Control Drawing 72979, and Pub 42004-222, Model 10468-002 Centra-Page Central Cabinet. Figure 3 below illustrates the wiring terminations inside the Model 476-002 Station.

Terminations L1, L2, P, and A correspond to identical terminations at the card rack assembly. These four connections must be complete as two pair. The first pair, L1 and L2, serves as both the communications path and the power supply. The second (control) pair provides party line selection or page line activation. Terminations M1 and M2 are not used in typical installation.

The speaker conductors are connected directly to the associated speaker or driver.

Installing a Model 476-002 in a Division 1 area requires that the four station conductors terminate in a safety barrier (10439-102) prior to entering the Division 1 area. This configuration creates intrinsically safe wiring to the station. Speaker wiring may not pass through the station. Refer to Pub. 42004-356 Control Drawing 72979 for proper installation.

The wiring distance limitation for a handset station is specified as 10,000 feet without a hazardous area safety barrier, and 3,000 feet with a barrier. This distance is determined by degradation from cable capacitance more than cable resistance: the use of heavier wire will not fully compensate for a greater distance.

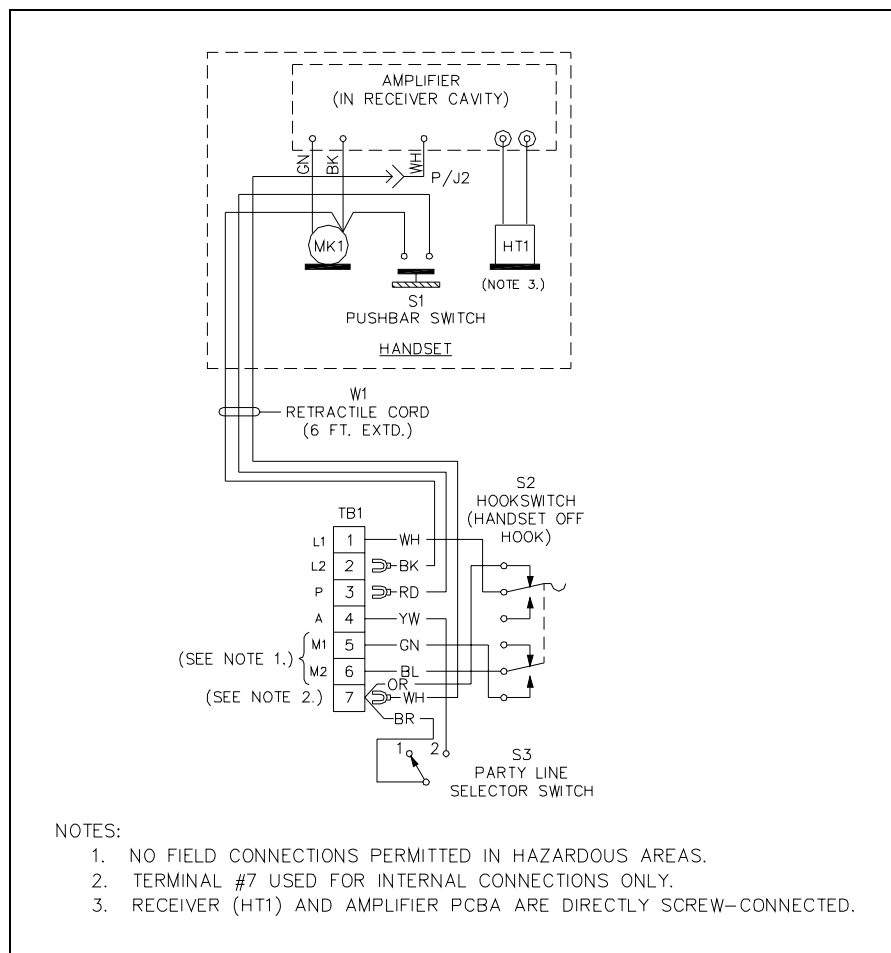

Figure 3. Station Wiring Details

Adjustments

After the station is installed and wired, the page speaker volume may require adjustment. This adjustment cannot be made at the station, but rather at the central cabinet/card rack. The page speaker volume control, R1 through R10, is accessible on the rear of the Model 10461-002 Station Card Rack Assembly. Making the adjustment requires one person near the speaker and one at the card rack in party line communication.

1. Identify the number of the station card connected to be adjusted.
2. Lift the handset connected to any station card except the one that is to be adjusted. This step is required only if that station is muted.
3. Adjust the control for the desired level while speaking into the handset with the handset pressbar depressed.

NOTES:

- **For alarm tone generation only:** If the station speaker is to broadcast only alarms, (remains silent during routine paging) rotate this control to the fully counterclockwise position.
- **For telephone interface only:** This control affects the level of the telephone interface call “birdie” but does NOT affect alarm signal levels.

If you are assembling the Centra-Page system in the field, refer to the specific instruction manuals for individual components, if used. These manuals explain in detail how to install and connect the various components of a Centra-Page system. The manuals for these components are listed below:

Pub. Number	Component/Title
42004-214	Model 476-002 Centra-Page Outdoor Wall Station
42004-215	Model 472-002 Centra-Page Permanent Indoor 2-Party Station
42004-220	Model 10461-002 Centra-Page Card Rack
42004-221	Model 69037-101 Centra-Page Station Card
42004-227	Model C83018 Centra-Page Station Crew's Quarters Muting Card
42004-222	Model 10468-002 Centra-Page Central Cabinet
42004-345	Model 10959-006 Rack-Mount Audio Messenger Interface
42004-371	Model 10961-001 AMI Centra-Page Interface

Operation

1. To generate a page, lift the handset, and check for an available party line.
2. Press the handset pressbar, and announce the page indicating which page line to use. The page is heard over the system speakers.
3. Release the pressbar and wait for a reply.
4. The paged individual goes to a handset station, uses the page line selector to select the specified party line, and lifts the handset to reply. Full-duplex communication can then take place.

Specifications

Electrical

Handset:

Microphone.....	10 ohms; pressure differential, noise-canceling dynamic
Receiver	150 ohms; high efficiency dynamic, hearing aid compatible
Cable	Retractable, 6 feet (1.82 m) extended PVC
Material	Light gray ABS
Controls	Handset pressbar

Frequency response.....	200-2,000 Hz, +/-3 dB
Distortion	Microphone input to receiver output 2% (nominal line level at 1 kHz)
Sidetone rejection.....	14 dB (nominal line level at 1 kHz)
DC line current	Each handset: 8 mA typical

Mechanical

Construction/finish.....	Cold-rolled steel/ gray baked enamel
External controls.....	Rotary party line selector switch
Mounting.....	Flush-mount in wall
Connections.....	Internal screw-type barrier terminal blocks
Operating temperature range.....	-22° F to +140° F (-30° C to 60° C)

Dimensions:

Front panel.....	6 H × 3.5 W inches (152.4 × 88.9 mm)
Behind panel.....	3.75 inches (95.2 mm)
Cutout.....	2.5 W × 4.86 H × 2.5 D inches (63.6 × 123.6 × 63.5 mm)

Shipping weight	6.8 lbs (3.1 kg)
-----------------------	------------------

Approvals

NRTL approved for use in US and Canada for the following hazardous locations:

Intrinsically safe for.....	Class I, Div. 1, Groups C and D hazardous locations when installed in accordance with Control Drawing No. 72979. Exia
Listed for use in.....	Class I, Div. 2, Groups C and D hazardous locations when installed in accordance with Control Drawing No. 72979

Replacement Parts

Part Number	Description
10450-004	Handset Assembly
13201-010	Handset Handle
13203-004	Transmitter Cap
13204-002	Receiver Cap

Warranty

Equipment. GAI-Tronics warrants for a period of one (1) year from the date of shipment, that any GAI-Tronics equipment supplied hereunder shall be free of defects in material and workmanship, shall comply with the then-current product specifications and product literature, and if applicable, shall be fit for the purpose specified in the agreed-upon quotation or proposal document. If (a) Seller's goods prove to be defective in workmanship and/or material under normal and proper usage, or unfit for the purpose specified and agreed upon, and (b) Buyer's claim is made within the warranty period set forth above, Buyer may return such goods to GAI-Tronics' nearest depot repair facility, freight prepaid, at which time they will be repaired or replaced, at Seller's option, without charge to Buyer. Repair or replacement shall be Buyer's sole and exclusive remedy. The warranty period on any repaired or replacement equipment shall be the greater of the ninety (90) day repair warranty or one (1) year from the date the original equipment was shipped. In no event shall GAI-Tronics warranty obligations with respect to equipment exceed 100% of the total cost of the equipment supplied hereunder. Buyer may also be entitled to the manufacturer's warranty on any third-party goods supplied by GAI-Tronics hereunder. The applicability of any such third-party warranty will be determined by GAI-Tronics.

Services. Any services GAI-Tronics provides hereunder, whether directly or through subcontractors, shall be performed in accordance with the standard of care with which such services are normally provided in the industry. If the services fail to meet the applicable industry standard, GAI-Tronics will re-perform such services at no cost to buyer to correct said deficiency to Company's satisfaction provided any and all issues are identified prior to the demobilization of the Contractor's personnel from the work site. Re-performance of services shall be Buyer's sole and exclusive remedy, and in no event shall GAI-Tronics warranty obligations with respect to services exceed 100% of the total cost of the services provided hereunder.

Warranty Periods. Every claim by Buyer alleging a defect in the goods and/or services provided hereunder shall be deemed waived unless such claim is made in writing within the applicable warranty periods as set forth above. Provided, however, that if the defect complained of is latent and not discoverable within the above warranty periods, every claim arising on account of such latent defect shall be deemed waived unless it is made in writing within a reasonable time after such latent defect is or should have been discovered by Buyer.

Limitations / Exclusions. The warranties herein shall not apply to, and GAI-Tronics shall not be responsible for, any damage to the goods or failure of the services supplied hereunder, to the extent caused by Buyer's neglect, failure to follow operational and maintenance procedures provided with the equipment, or the use of technicians not specifically authorized by GAI-Tronics to maintain or service the equipment. **THE WARRANTIES AND REMEDIES CONTAINED HEREIN ARE IN LIEU OF AND EXCLUDE ALL OTHER WARRANTIES AND REMEDIES, WHETHER EXPRESS OR IMPLIED BY OPERATION OF LAW OR OTHERWISE, INCLUDING ANY WARRANTIES OF MERCHANTABILITY OR FITNESS FOR A PARTICULAR PURPOSE.**

Return Policy

If the equipment requires service, contact your Regional Service Center for a return authorization number (RA#). Equipment should be shipped prepaid to GAI-Tronics with a return authorization number and a purchase order number. If the equipment is under warranty, repairs or a replacement will be made in accordance with the warranty policy set forth above. Please include a written explanation of all defects to assist our technicians in their troubleshooting efforts.

Call 800-492-1212 (inside the USA) or 610-777-1374 (outside the USA) for help identifying the Regional Service Center closest to you.