



GAI-TRONICS® CORPORATION  
A HUBBELL COMPANY

# Model 780-001, 785-001, 7805-001, and 7855-001 Explosion-proof Handset Stations

---

## Confidentiality Notice

This manual is provided solely as an operational, installation, and maintenance guide and contains sensitive business and technical information that is confidential and proprietary to GAI-Tronics. GAI-Tronics retains all intellectual property and other rights in or to the information contained herein, and such information may only be used in connection with the operation of your GAI-Tronics product or system. This manual may not be disclosed in any form, in whole or in part, directly or indirectly, to any third party.

## General Information

GAI-Tronics hazardous area Page/Party® handset stations are designed to provide safe and clear communications in hazardous areas, even in high-noise situations. These models are NRTL certified for use in the US and Canada for the following areas: Class I, Div. 1, Groups C and D; Class II, Div. 1, Groups E, F, and G; and Class III, Div. 1.

Each of these models includes a front-panel push button for paging, a 6-foot PVC coil cord, a noise-canceling microphone for reduced transmission of background noise, and sidetone circuitry to reduce amplification of the user's voice and background noise into their earpiece. An electrical safety barrier mounted inside the housing creates an intrinsically-safe handset. Multi-party stations include a durable rotary switch for party line selection. The weatherproof stations include a nonmetallic housing with a front door. This installation manual covers the following models:



Model	Description
780-001	Explosion-proof Handset Station, indoor, 120 V ac, single party
7805-001	Explosion-proof Handset Station, indoor, 120 V ac, multi-party
785-001	Explosion-proof Handset Station, weatherproof, 120 V ac, single party
7855-001	Explosion-proof Handset Station, weatherproof, 120 V ac, multi-party

This manual provides instructions for station placement and mounting. Refer to Pub. 42004-184, 42004-238, or 42004-239, as applicable, for information detailing how to maintain the explosion-proof integrity of the stations. The appropriate publication is packed with each station.

**⚠ WARNING ⚠ Explosion Hazard – Do not connect or disconnect equipment unless power has been switched off or the area is known to be non-hazardous.**

## Installation

Whether installing an entire system or only an add-on station, consult the system layout diagrams at the end of this manual. These figures, used in conjunction with the station installation information and the cable layout guide, should provide all the information necessary to install the Page/Party® stations. These figures do not show an explosion-proof station; however, the basic points of the system layout and design still apply.

 **NOTE**  A separate power feed is recommended for Page/Party® stations in Div.1 areas. With a separate power feed, the Page/Party® stations can be shut off for maintenance without disrupting the power supply to the other equipment in the Div. 1 area.

## Enclosure Placement

All GAI-Tronics Page/Party® units are wired in parallel. Good system layout design minimizes the cable required for each installation. GAI-Tronics multi-conductor cable, designed especially for this application, is recommended. The number, size, and color-coding of conductors are listed in the accompanying system connection diagrams.

System layout and power cable length are important considerations when installing Page/Party® equipment. The rules vary for different systems, but generally, the total power cable length should not exceed one mile (5280 feet) for 115 V ac systems. The length of cable between the stations is not a factor; the total cable length is the most important consideration.

## Mounting

To maintain the explosion-proof integrity of these stations, all mounting hardware is located outside the aluminum enclosure. The suggested mounting height for all station enclosures is 54 inches (137 mm) up to the centerline of the enclosure.

*Indoor Station:* Mount the indoor unit using the two mounting straps on the rear of the enclosure. Refer to Figure 1. Use the standard  $\frac{3}{8}$ -inch bolts to secure the enclosure to the mounting surface. Secure the two bottom bolts first, then the top bolts. The mounting strap design allows the station to be removed from its mounting surface by removing only two of the bolts.

*Outdoor Station:* The outdoor model stations are shipped with a separate glass-reinforced polyester enclosure with a front door. This enclosure has four 0.44-inch diameter mounting feet in the 4 corners and is suitable for mounting to many types of surfaces. Refer to Figure 2.

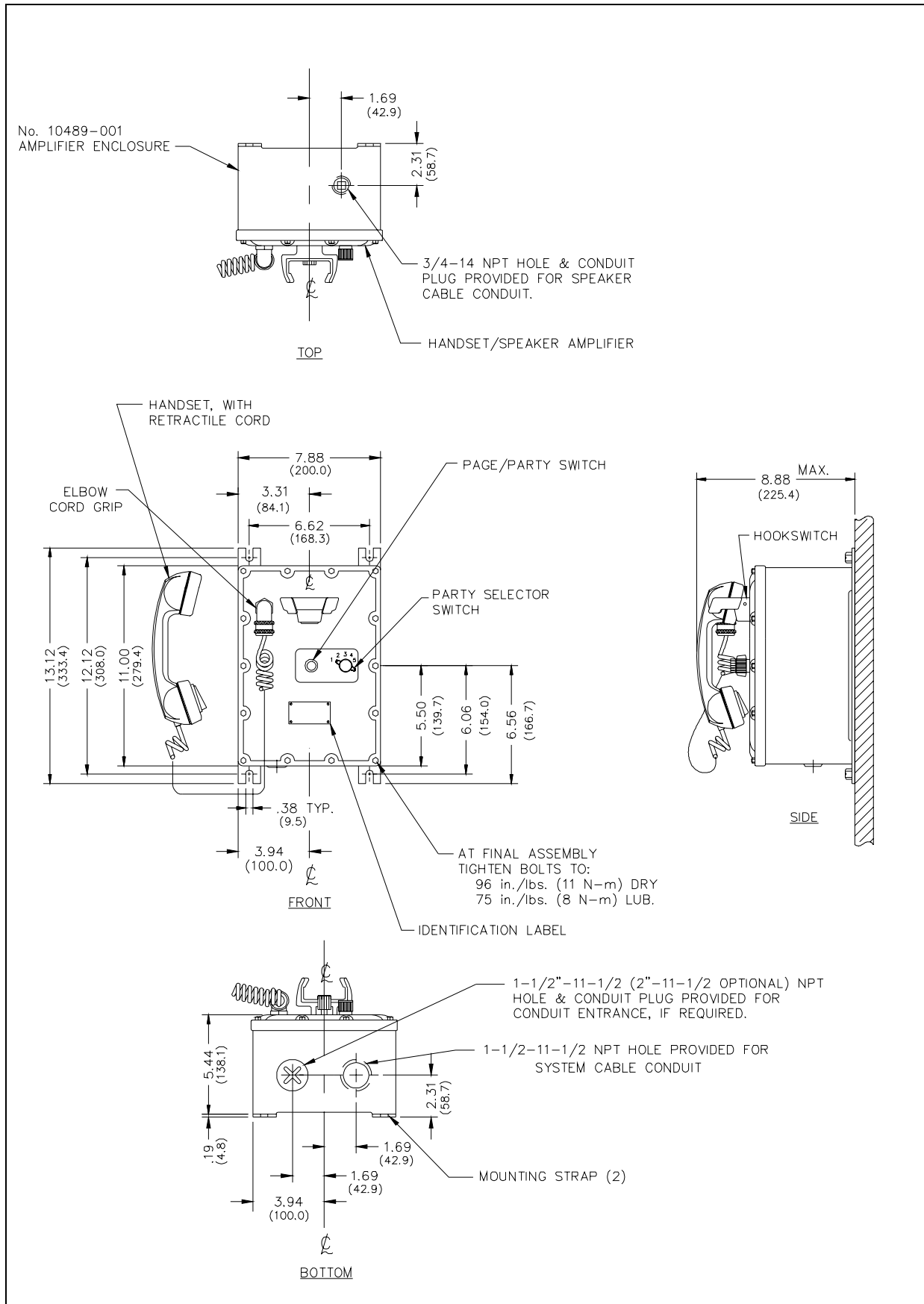

Figure 1. Mounting details for indoor stations

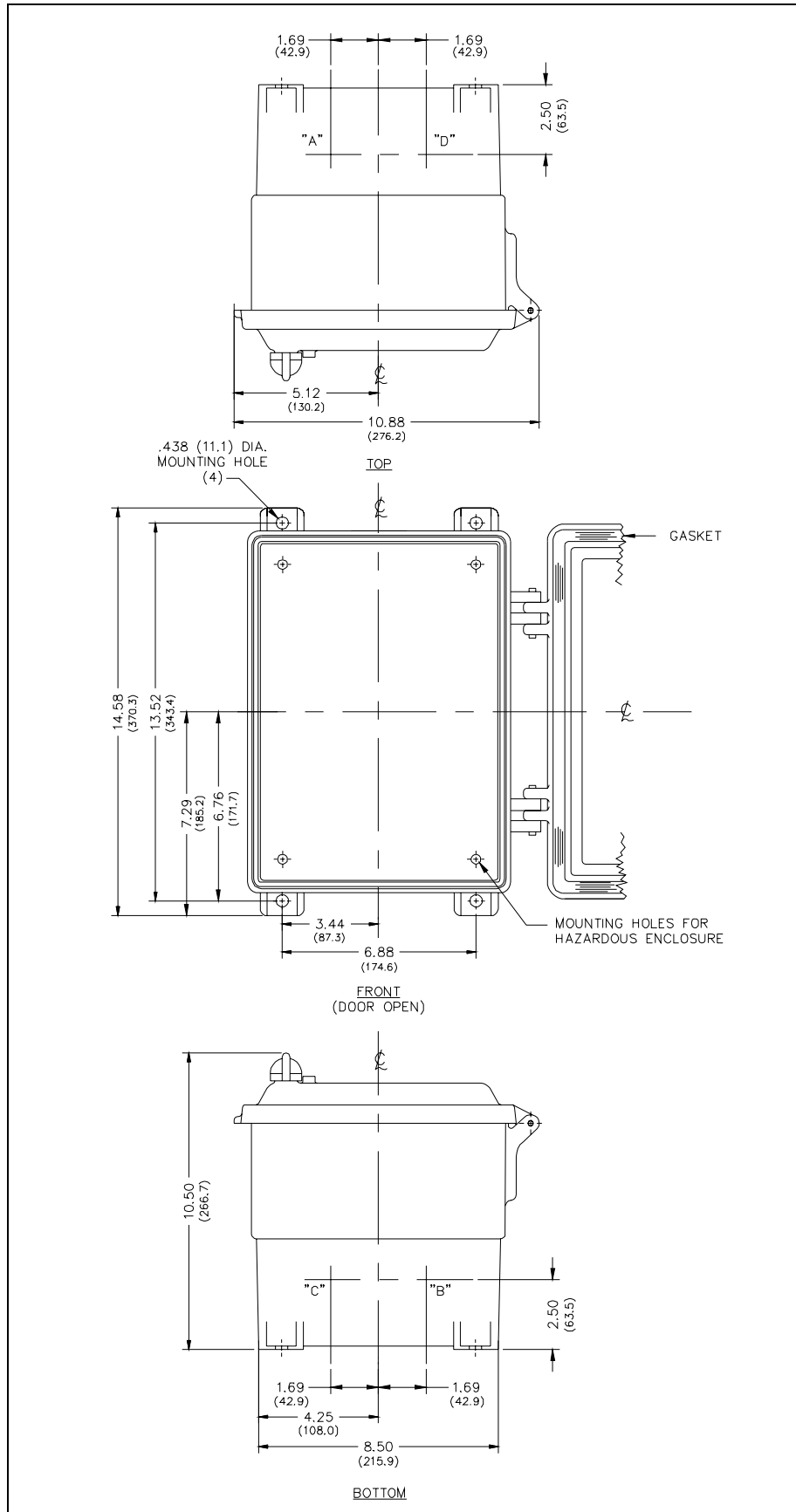



Figure 2. Mounting details for outdoor stations (multi-party station shown)

## Conduit Installation

Refer to Pub. 42004-184 (US), 42004-238 (Canada) 42004-239 (Canada), as applicable. These publications detail how to maintain the integrity of the explosion-proof stations.



 **NOTE**  **External conduits in Class I, Groups C and D areas must have gas seals not more than 18 inches (457 mm) from the station enclosure. External conduits in Class II and Class III areas must have seals if the conduit system is not dust-tight.**

## Wiring

After the station is mounted, use a 7/16-inch wrench to open the front cover to access the Termination PCBA. Refer to Pub. 42004-184 (US), and 42004-238 (Canada) or 42004-239 (Canada), as applicable for wiring details.

Feed the wiring through the conduit and into the enclosure. Follow the wire colors carefully—these colors correspond to GAI-Tronics 60029 or 60038 Series cable. The wires must be spade-lugged and connected carefully and completely to the terminal block. An improper termination may result in diminished station performance.

Before closing the station cover, plug the power interconnect cable from the front of the enclosure into the connector on the power supply card in the rear enclosure.

 **NOTE**  **All the bolts must be installed to maintain the integrity of the explosion-proof construction.**

## Speaker Muting Information

These stations are equipped with a muting feature that is used if the station is located near other handset/speaker stations. This feature prevents acoustic feedback between stations during paging by muting the station's associated speaker. These stations are shipped from the factory with the mute feature enabled.

To disable the muting feature, remove jumper W6 located on the 10489-001 Termination PCBA. The chart below describes how the muting function operates when specific combinations of wire jumpers W3, W4, W5, and W6 are installed on the Termination PCBA.

W3	W4	W5	W6	Description of Muting Function Operation
O	X	X	X	The AUX/PAGE inputs to the amplifier are muted during station page (as shipped from GAI-Tronics).
O	X	X	O	The AUX/PAGE inputs to the amplifier are not muted during a station page.
O	X	O	X	Mute the PAGE input only during a station page.
X	X	O	X	The PAGE input is muted during a station page or by contact closure between the Mute A and B inputs.
X	O	X	X	The PAGE/AUX inputs are muted during a station page or by contact closure between the Mute A and B inputs.
X	O	O	O	The PAGE/AUX inputs are not muted. Isolated normally open relay contact output between the Mute A and B terminals is closed during station pages.

X = Installed                      O = Not Installed.

### Mutual Muting

Stations that are located closely together may require *mutual muting* of the page amplifiers. To set up mutual muting between stations, connect the orange (spare) wire in the GAI-Tronics station cable to TB2-11(A) on each of the Div. 1 stations that require muting. All the mutually muted stations are then muted when any connected station is paging.

**NOTE:** Jumpers W4, W5, and W6 must be installed.

Mutual muting can be accomplished between the Div. 1 stations and Div. 2 enclosures using most GAI-Tronics 600 or 700 Series enclosures by connecting the orange (spare) wire between TB2-11(A) on the Div. 1 station and TB1-7 on the Div. 2 enclosure:

Div. 1 Stations TB2-11(A)	Div. 2 Enclosures (TB1-7)		
7805-001	702A	758-001	7335-001
780-001	732-101	703A	
670-001	7325-101	733-001	

Consult GAI-Tronics for any enclosures not listed.

**NOTE:** The auxiliary speaker amplifier input is a balanced 10 kilohm audio input.

## Operation

GAI-Tronics offers two types of Page/Party<sup>®</sup> systems: Single party with one page line and one party line, and multi-party with one page line and five party lines allowing up to five simultaneous two-way conversations.

For *single party* systems, complete the following steps to make a page announcement:

1. Lift the handset from the cradle.
2. Depress and hold the handset pressbar.
3. Speak directly into the microphone to broadcast your announcement over the loudspeakers.
4. Release the handset pressbar, and if requested, wait for a response.

The paged individual(s) responds by picking up a station handset.

For *multi-party* systems, complete the following steps to make a page announcement:

1. Lift the handset from the cradle. If party line conversation is desired, rotate the selector switch to an unoccupied party line.
2. Depress and hold the handset pressbar.
3. Speak directly into the microphone to broadcast your announcement over the loudspeakers.
4. Release the handset pressbar, and if requested, wait for a response.

The paged individual(s) responds by picking up a station handset and turning the selector switch to the requested party line.

With either type of system, the full duplex party line communication is not broadcast over the system speakers. Other individuals can also pick up and join the conversation at any time. Always return the handset to the cradle following a page or a party line conversation.

## Maintenance

The following adjustments are accessible through the rear amplifier chassis using a small screwdriver. The handset/speaker amplifier section must be completely removed from the enclosure to access these controls. A silk-screen on the rear of the amplifier identifies the following controls.

- *Microphone Gain*: adjusts the gain level from the microphone signal to the page or party lines.
- *Receiver Sidetone*: adjusts the amount of signal transmitted from the microphone to the receiver. To properly adjust the sidetone, blow into the handset microphone while turning the sidetone adjustment. The sidetone is correctly set when the person blowing into the handset can barely hear themselves.
- *Receiver Volume*: adjusts the gain level from the party line to the receiver.
- *Speaker Volume*: adjusts the volume level of the speaker (if any) associated with this station.

## Troubleshooting

The following table lists some hints to aid technicians in troubleshooting.

Problem	Solution
Outgoing conversation level requires adjustment.	Adjust the microphone gain at the amplifier.
Incoming conversation level requires adjustment.	Adjust the receiver volume control at the amplifier.
Sidetone (how the operator hears himself) requires adjustment.	<ol style="list-style-type: none"> <li>1. Adjust the receiver sidetone at the amplifier.</li> <li>2. Check that the system cable connections to the resistors in the line balance assembly are properly terminated.</li> </ol>
Feedback occurs only during page.	Ensure the muting feature is enabled. See the Mutual Muting section of this manual for details.
Crosstalk occurs.	One or more system cable pairs may be improperly terminated. Visually inspect the system cable connections for accidental crossing of the cable pairs or grounds.

# Specifications

Power input ..... 90–140 V ac; 120 V ac nominal, 50–60 Hz; 0.5 amp maximum

## Dimensions:

Indoor stations ..... 13.1 H × 7.9 W × 5.6 D (8.9 including handset) inches; (332 × 200 × 143 mm)

Outdoor stations..... 14.6 H × 10.9 W × 10.5 D inches; (371 × 276 × 226 mm)

Temperature range..... -22° F to +158° F (-30° C to +70° C)

Shipping weight ..... Indoor: 27 lbs. (12.2 kg); outdoor: 35 lbs. (11.7 kg)

## Handset

Material/finish ..... Gray ABS

Microphone ..... 10 ohms, noise-canceling, dynamic

Receiver ..... 150 ohms, dynamic

Cable..... Retractable with sealed elbow, 6-foot extended length

## Handset Amplifier

Output ..... 1.5 V nominal into 33-ohm load

Gain ..... 55 dB, adjustable

Frequency response..... 250–4000 Hz, +0/-3 dB ref @ 1 kHz (1.5 V<sub>RMS</sub>) output

Distortion ..... 1.5% maximum THD @ 1 kHz

Preset adjustments ..... Microphone gain, sidetone adjustment, receiver volume

## Speaker Amplifier

Output ..... @ 120 V ac: 12 watt minimum into 8- or 16-ohm load

Voltage gain ..... 20 dB minimum, adjustable

Frequency response..... 250–4000 Hz; +0/-3 dB ref @ 1 kHz

Distortion ..... 1% maximum THD @ 1 kHz/12 watts

Input impedance..... 50,000 ohm, minimum @ 1 kHz

Controls, preset adjustments..... Speaker volume

## Explosion-proof Enclosure

Material/finish ..... Aluminum alloy

Mounting..... Wall or column, four 3/8-inch slotted mounting feet

Connections ..... Internal screw-type barrier terminal blocks

Conduit entry..... Standard hole size top: 3/4 NPT; standard size hole bottom 1 1/2-inch NPT

## Weatherproof Enclosure

Material/finish ..... Glass-reinforced polyester

Mounting..... Wall or column

Environmental rating..... NEMA 4X

## Approvals

NRTL certified for use in US and Canada ..... Class I, Div. 1, Groups C and D

Class II, Div. 1, Groups E, F, and G

Class III, Div. 1

## Replacement Parts

Part No.	Description	780-001	785-001	7805-001	7855-001
10108-007	Handset Assembly, 6-foot coil cord	■	■	■	■
10108-008	Handset Assembly, 15-foot coil cord	■	■	■	■
10108-009	Handset Assembly, 25-foot coil cord	■	■	■	■
10444-003	Weatherproof Enclosure		■		■
12251-001	Spring Door Kit		■		■
12502-101	Receiver Kit	■	■	■	■
12504-004	Replacement Door Handle		■		■
12505-004	Replacement Door Kit		■		■
12505-005	Replacement Door Kit		■		■
12511-001	Dynamic Transmitter and Cap	■	■	■	■
12519-001	Replacement Hook and Hinge Kit	■	■	■	■
12604-001	Fuse, 0.7A, (10 pack)	■	■	■	■
12604-002	Fuse, 1/16A, (10 pack)	■	■	■	■
13204-002	Receiver Cap	■	■	■	■
24201-009	Page Switch Knob	■	■	■	■
24201-010	Party-line Switch Knob			■	■
12542-001	Replacement Front Cover Bolts (14 pack)	■	■	■	■
61514-004	Harness Assembly	■	■	■	■
69012-002	PCBA Handset Safety Barrier	■	■	■	■
69488-101	PCBA Handset/Speaker Amplifier	■	■		
69488-102	PCBA Handset/Speaker Amplifier			■	■
69489-001	PCBA Termination	■	■	■	■
12571-001	Maintenance Cover Kit	■	■	■	■

TYPICAL MULTI-PARTY SYSTEM CONNECTION DIAGRAM

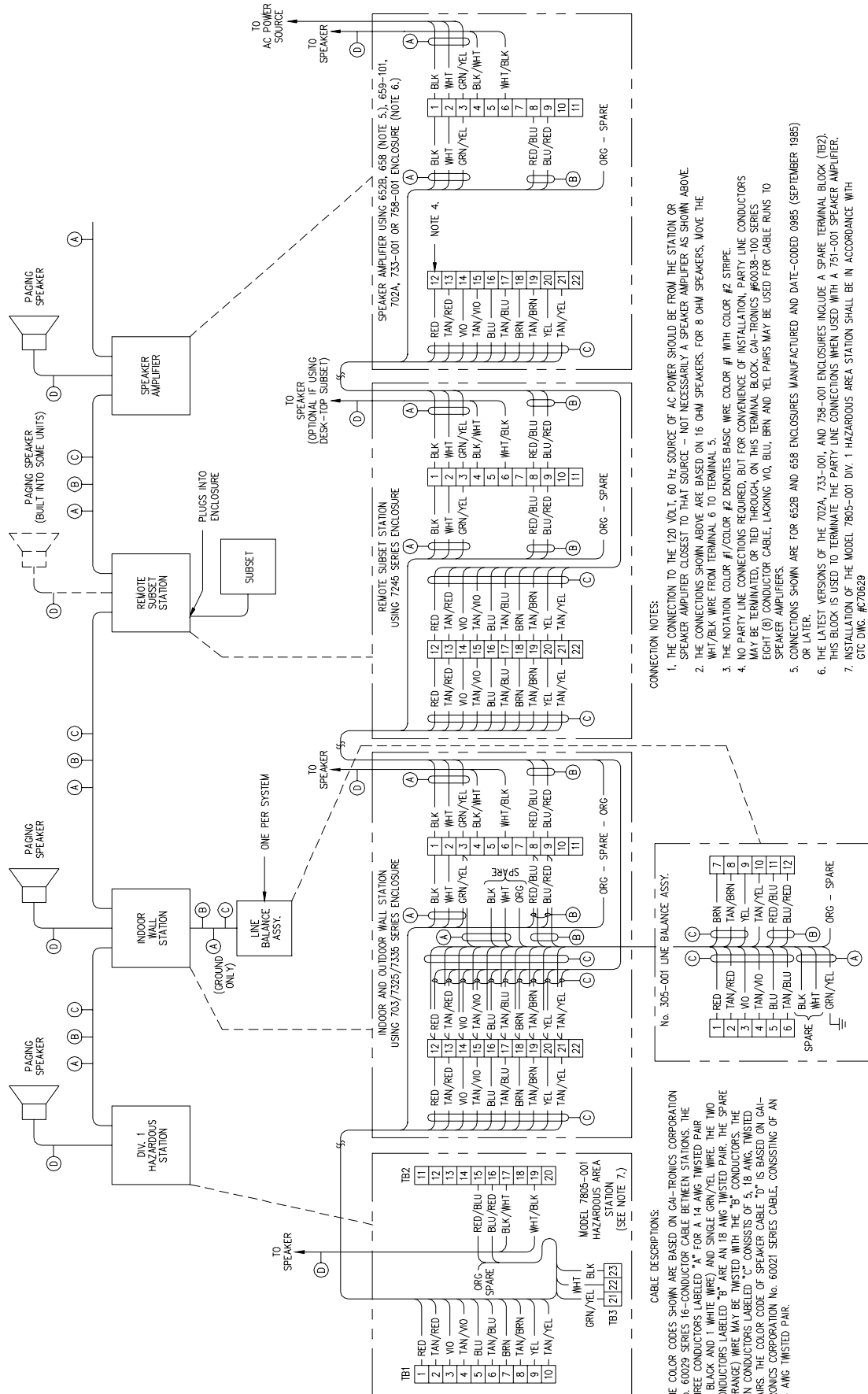

TYPICAL SINGLE-PARTY SYSTEM CONNECTION DIAGRAM

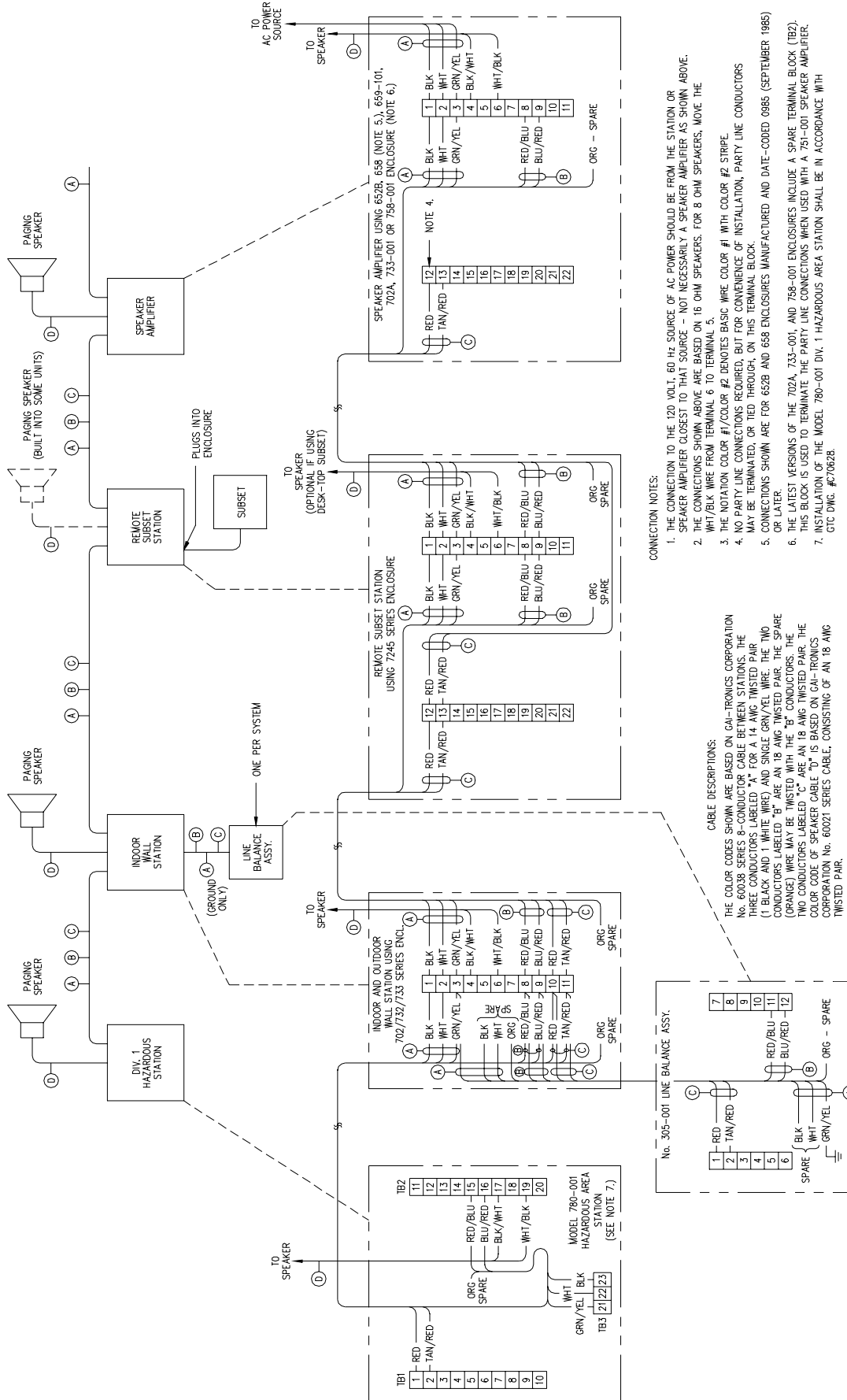

# Warranty

---

Equipment. GAI-Tronics warrants for a period of one (1) year from the date of shipment, that any GAI-Tronics equipment supplied hereunder shall be free of defects in material and workmanship, shall comply with the then-current product specifications and product literature, and if applicable, shall be fit for the purpose specified in the agreed-upon quotation or proposal document. If (a) Seller's goods prove to be defective in workmanship and/or material under normal and proper usage, or unfit for the purpose specified and agreed upon, and (b) Buyer's claim is made within the warranty period set forth above, Buyer may return such goods to GAI-Tronics' nearest depot repair facility, freight prepaid, at which time they will be repaired or replaced, at Seller's option, without charge to Buyer. Repair or replacement shall be Buyer's sole and exclusive remedy. The warranty period on any repaired or replacement equipment shall be the greater of the ninety (90) day repair warranty or one (1) year from the date the original equipment was shipped. In no event shall GAI-Tronics warranty obligations with respect to equipment exceed 100% of the total cost of the equipment supplied hereunder. Buyer may also be entitled to the manufacturer's warranty on any third-party goods supplied by GAI-Tronics hereunder. The applicability of any such third-party warranty will be determined by GAI-Tronics.

Services. Any services GAI-Tronics provides hereunder, whether directly or through subcontractors, shall be performed in accordance with the standard of care with which such services are normally provided in the industry. If the services fail to meet the applicable industry standard, GAI-Tronics will re-perform such services at no cost to buyer to correct said deficiency to Company's satisfaction provided any and all issues are identified prior to the demobilization of the Contractor's personnel from the work site. Re-performance of services shall be Buyer's sole and exclusive remedy, and in no event shall GAI-Tronics warranty obligations with respect to services exceed 100% of the total cost of the services provided hereunder.

Warranty Periods. Every claim by Buyer alleging a defect in the goods and/or services provided hereunder shall be deemed waived unless such claim is made in writing within the applicable warranty periods as set forth above. Provided, however, that if the defect complained of is latent and not discoverable within the above warranty periods, every claim arising on account of such latent defect shall be deemed waived unless it is made in writing within a reasonable time after such latent defect is or should have been discovered by Buyer.

Limitations / Exclusions. The warranties herein shall not apply to, and GAI-Tronics shall not be responsible for, any damage to the goods or failure of the services supplied hereunder, to the extent caused by Buyer's neglect, failure to follow operational and maintenance procedures provided with the equipment, or the use of technicians not specifically authorized by GAI-Tronics to maintain or service the equipment. **THE WARRANTIES AND REMEDIES CONTAINED HEREIN ARE IN LIEU OF AND EXCLUDE ALL OTHER WARRANTIES AND REMEDIES, WHETHER EXPRESS OR IMPLIED BY OPERATION OF LAW OR OTHERWISE, INCLUDING ANY WARRANTIES OF MERCHANTABILITY OR FITNESS FOR A PARTICULAR PURPOSE.**

## Return Policy

---

If the equipment requires service, contact your Regional Service Center for a return authorization number (RA#). Equipment should be shipped prepaid to GAI-Tronics with a return authorization number and a purchase order number. If the equipment is under warranty, repairs or a replacement will be made in accordance with the warranty policy set forth above. Please include a written explanation of all defects to assist our technicians in their troubleshooting efforts.

Call 800-492-1212 (inside the USA) or 610-777-1374 (outside the USA) for help identifying the Regional Service Center closest to you.