



GAI-TRONICS® CORPORATION
A HUBBELL COMPANY

Replacement Door Kit for Weatherproof Enclosures

Model 12505-001

Confidentiality Notice

This manual is provided solely as an operational, installation, and maintenance guide and contains sensitive business and technical information that is confidential and proprietary to GAI-Tronics. GAI-Tronics retains all intellectual property and other rights in or to the information contained herein, and such information may only be used in connection with the operation of your GAI-Tronics product or system. This manual may not be disclosed in any form, in whole or in part, directly or indirectly, to any third party.

General Information

The Model 12505-001 Replacement Door Kit is for use on the following GAI-Tronics weatherproof enclosures:

632	648	732	10437-001	10437-003
6325	6485	7325	10437-002	211A

This kit includes the following components:

Item	Qty.	Description
1	1	Door
2	2	Washer
3	2	Hinge pin
4	4	Pin retainer
5	1	Gasket

Installation

Unpack the material and compare parts to the list below to ensure that all parts are present.

(NOTE: A ¼-inch hex nut driver is required for some assembly.)

1. Remove the two hinge pins by driving the upper pin downward and the lower pin upward.
2. After removing the old door from the enclosure, check the fit and clearance of the replacement door by placing the door assembly onto the enclosure. Place two washers (item 2) between the upper and lower door and enclosure hinge bosses. File the material from the door bosses if more clearance is required.

MODEL 12505-001 REPLACEMENT DOOR KIT

3. After ensuring proper fit and clearance, slide one pin retainer (item 4) onto each hinge pin (item 3). Position the pin retainer such that it is 1/16 inch from the end of the hinge pin.
4. Position the door assembly onto the enclosure and place one washer (item 2) between the upper door boss and the enclosure boss. In an upward position, insert the pin, with the retainer installed, through hinge pin holes of the enclosure boss, washer, and door boss.
5. Insert the lower hinge pin, with the retainer installed, in a downward direction through the hinge pin holes in the enclosure boss, washer and door boss.
6. Install the upper pin retainer by placing it on top of the upper hinge pin and then pushing downward with the 1/4-inch hex nut driver, while at the same time applying pressure at the bottom of the hinge pin. The pin retainer should be pushed onto the hinge until both pin retainers are touching the bosses of the door and enclosure.
7. Place the pin retainer on the opening of the 1/4-inch hex nut driver and by pushing upward, install onto the lower hinge pin, while applying downward pressure on the hinge pin. Pin retainers should touch the bosses of the door and enclosure.

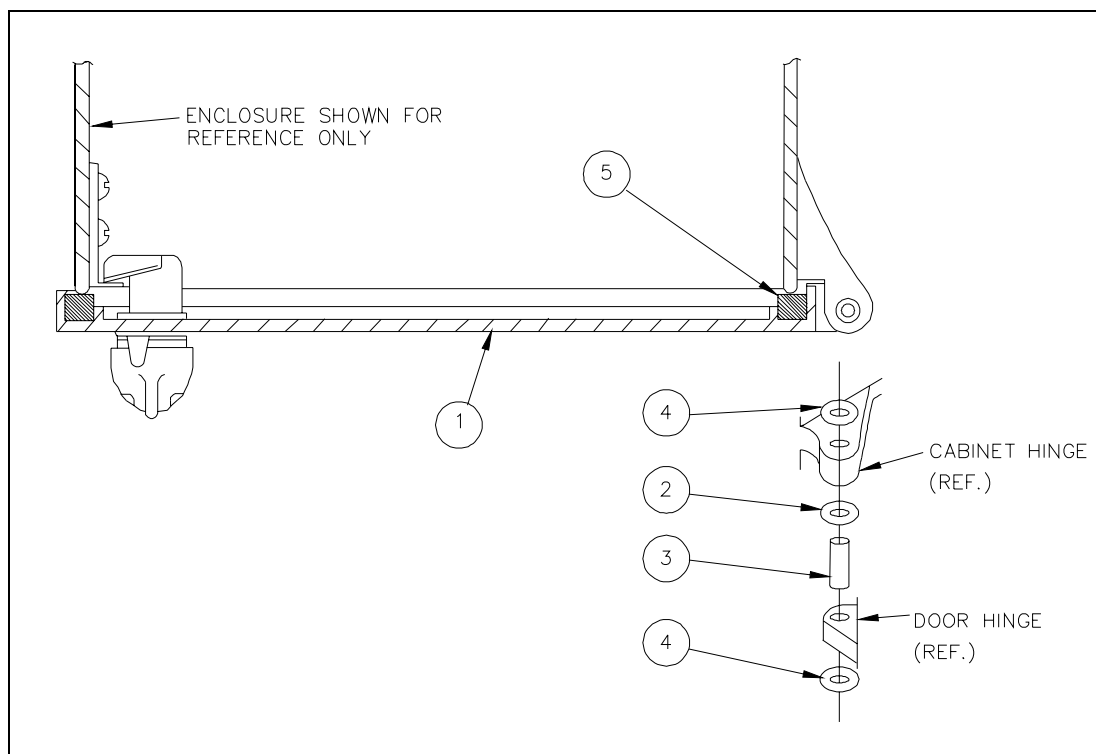

Figure 1.

Warranty

Equipment. GAI-Tronics warrants for a period of one (1) year from the date of shipment, that any GAI-Tronics equipment supplied hereunder shall be free of defects in material and workmanship, shall comply with the then-current product specifications and product literature, and if applicable, shall be fit for the purpose specified in the agreed-upon quotation or proposal document. If (a) Seller's goods prove to be defective in workmanship and/or material under normal and proper usage, or unfit for the purpose specified and agreed upon, and (b) Buyer's claim is made within the warranty period set forth above, Buyer may return such goods to GAI-Tronics' nearest depot repair facility, freight prepaid, at which time they will be repaired or replaced, at Seller's option, without charge to Buyer. Repair or replacement shall be Buyer's sole and exclusive remedy. The warranty period on any repaired or replacement equipment shall be the greater of the ninety (90) day repair warranty or one (1) year from the date the original equipment was shipped. In no event shall GAI-Tronics warranty obligations with respect to equipment exceed 100% of the total cost of the equipment supplied hereunder. Buyer may also be entitled to the manufacturer's warranty on any third-party goods supplied by GAI-Tronics hereunder. The applicability of any such third-party warranty will be determined by GAI-Tronics.

Services. Any services GAI-Tronics provides hereunder, whether directly or through subcontractors, shall be performed in accordance with the standard of care with which such services are normally provided in the industry. If the services fail to meet the applicable industry standard, GAI-Tronics will re-perform such services at no cost to buyer to correct said deficiency to Company's satisfaction provided any and all issues are identified prior to the demobilization of the Contractor's personnel from the work site. Re-performance of services shall be Buyer's sole and exclusive remedy, and in no event shall GAI-Tronics warranty obligations with respect to services exceed 100% of the total cost of the services provided hereunder.

Warranty Periods. Every claim by Buyer alleging a defect in the goods and/or services provided hereunder shall be deemed waived unless such claim is made in writing within the applicable warranty periods as set forth above. Provided, however, that if the defect complained of is latent and not discoverable within the above warranty periods, every claim arising on account of such latent defect shall be deemed waived unless it is made in writing within a reasonable time after such latent defect is or should have been discovered by Buyer.

Limitations / Exclusions. The warranties herein shall not apply to, and GAI-Tronics shall not be responsible for, any damage to the goods or failure of the services supplied hereunder, to the extent caused by Buyer's neglect, failure to follow operational and maintenance procedures provided with the equipment, or the use of technicians not specifically authorized by GAI-Tronics to maintain or service the equipment. **THE WARRANTIES AND REMEDIES CONTAINED HEREIN ARE IN LIEU OF AND EXCLUDE ALL OTHER WARRANTIES AND REMEDIES, WHETHER EXPRESS OR IMPLIED BY OPERATION OF LAW OR OTHERWISE, INCLUDING ANY WARRANTIES OF MERCHANTABILITY OR FITNESS FOR A PARTICULAR PURPOSE.**

Return Policy

If the equipment requires service, contact your Regional Service Center for a return authorization number (RA#). Equipment should be shipped prepaid to GAI-Tronics with a return authorization number and a purchase order number. If the equipment is under warranty, repairs or a replacement will be made in accordance with the warranty policy set forth above. Please include a written explanation of all defects to assist our technicians in their troubleshooting efforts.

Call 800-492-1212 (inside the USA) or 610-777-1374 (outside the USA) for help identifying the Regional Service Center closest to you.