



GAI-TRONICS® CORPORATION  
A HUBBELL COMPANY

# Model 7325-104 Outdoor Metallic Emergency Party Line Amplifier Enclosure

---

## General Information

The Model 7325-104 Outdoor Metallic Emergency Party Line Amplifier Enclosure is designed to be a component in a GAI-Tronics SmartSeries system. It is a multi-party, 115 V amplifier enclosure that mates with a Model 701-80x or 701-90x Series Handset/Speaker Amplifier to form a SmartSeries station.

When connected to a SmartSeries system, this station is equipped to report the following information when the handset is taken off-hook:

- Zone number
- Station address
- Party line (1 or 2)

All station reports are received by the Master Control Unit and annunciated on an access panel located in the SmartSeries control cabinet.

### NOTES:

1. The Model 7325-104 Enclosure can also mate with a standard 701 or 751 Series Amplifier; however the reporting feature is not operable with this combination.
2. Emergency party line functionality is only possible if the system's software is properly configured. The system must also have the address of the station intended to mate with the enclosure enabled. If there are questions as to the capabilities of the system, please contact the nearest GAI-Tronics Service Center.

## Specifications

Construction/finish.....	Sand-cast aluminum alloy, cam-style latch, hinged door with gasket; gray baked enamel
Mounting.....	Wall, column, or pole (mounting kit required for pole mount), four 7/16-inch mounting holes
Connections.....	Internal screw-type barrier terminal blocks
Dimensions.....	14.9 H × 10.8 W × 9.6 D inches (378 × 274 × 244 mm)
Shipping weight.....	20.4 lbs. (9.3 kg)
Approvals.....	NRTL Listed for USA and Canada..... Class I, Div. 2, Groups A, B, C, D; Class II, Div. 2, Groups F and G; Class III, Div. 2
Outdoor environmental rating.....	NEMA 3R

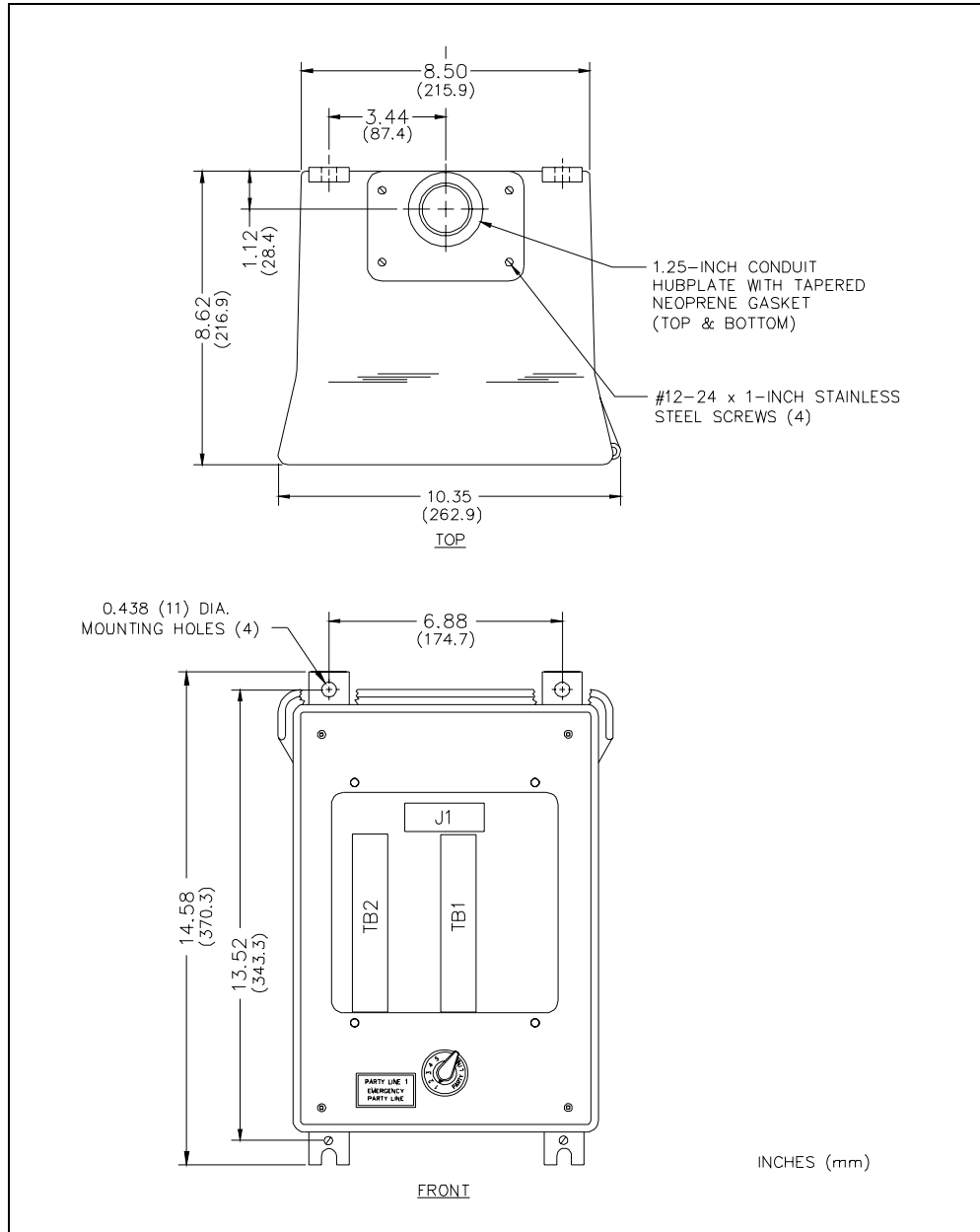

Figure 1. Model 7325-104 Metallic Enclosure Mounting Details