



GAI-TRONICS® CORPORATION
A HUBBELL COMPANY

Model GC-AC1, GC-DC1, and GC-AC2 EZ Page Industrial Intercoms

Confidentiality Notice

This manual is provided solely as an operational, installation, and maintenance guide and contains sensitive business and technical information that is confidential and proprietary to GAI-Tronics. GAI-Tronics retains all intellectual property and other rights in or to the information contained herein, and such information may only be used in connection with the operation of your GAI-Tronics product or system. This manual may not be disclosed in any form, in whole or in part, directly or indirectly, to any third party.

General Information

Product Overview

GAI-Tronics' EZ Page Intercoms are designed for two-way communication in non-hazardous, industrial applications. Each model is field configurable for one of two types of systems: either Listen/Talk or Master/Slave. All units are factory-configured for the *Listen/Talk* system.

Listen/Talk System

In a Listen/Talk system, the press-to-talk switch must be held down as long as the operator talks. Releasing the switch deactivates the microphone and returns the unit to the listen mode.

Master/Slave System

In a Master/Slave system the Master unit controls the talk/listen operation of the Slave unit. The Slave unit is normally in the talk mode, providing hands-free communication to the operator. The Master/Slave system is ideal for typical gate station applications. An internal switch is used to designate a unit as a master or as a slave.

Balanced and Unbalanced Systems

The EZ Page system is a balanced system; however, it can be adapted for use in an unbalanced system. If interfacing this equipment with other similar products on the market, determine if your system is balanced or unbalanced.

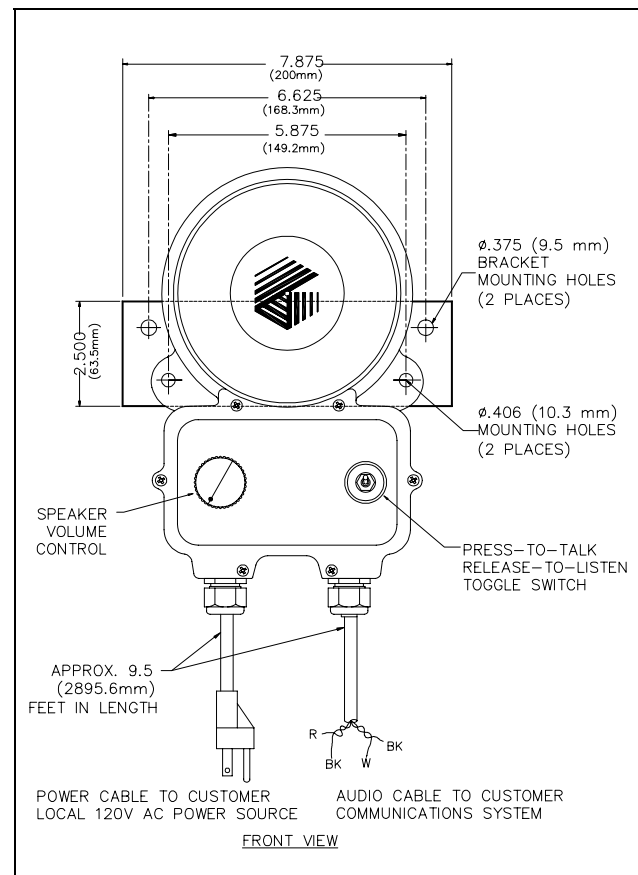

Figure 1. Intercom Outline Diagram
(shown with optional mounting bracket installed)

The setting of an internal jumper and the external wiring interconnection scheme are different in a balanced system and an unbalanced system. Refer to the appropriate installation instructions provided in this manual.

System Requirements

Each unit requires local power within approximately 9.5 feet of unit for interconnection of unit's audio/control cable to system cable.

NOTE: If applicable local electrical codes permit, the use of a combined UL-approved junction box for termination of the unit's local power connection and audio/control to system cable could be helpful.

Cable Distance Limitations

NOTE: Calculations are based on the use of No. 18 AWG twisted pair wire.

Audio Pair

Maximum distance from the line balance is approximately 1 mile (1.6 km). Maximum distance between the two end units is approximately 2 miles (3.2 km).

Models	Input Voltage	Interconnection (Customer-supplied)
GC-AC1	120 V ac	NEMA 5-15R style receptacle
GC-DC1	12-16 V dc	Small junction box for Class 2 wiring
GC-AC2	230 V ac	Small UL-approved junction box or plug rated for this voltage

External Control Pair



Maximum distance between the two end units is approximately 2 miles (3.2 km).

System Cable

Recommend use of twisted, two pair cable (No. 18 AWG) between stations for maximum system hum/noise immunity. Extreme hum/noise areas may require shielded twisted, two pair cable.

Installation

Since a good installation is important in obtaining the best possible performance of the communications system, determine the operating mode of each unit and carefully plan the overall installation before actual work is started. Read the entire procedure and the many suggestions offered to help you plan your installation.

 **DANGER**  **Do not install in a hazardous area.** Use in safe, non-classified, non-hazardous areas only.

 **WARNING**  **Please adhere to all the following safety and operating instructions on the unit and in the installation manual:**

- Ensure that the installation is in accordance with all local applicable electrical codes.
- Disconnect power to the unit before opening or servicing to avoid possible damage to equipment or personal injury.
- Avoid running system cable near high voltage/high electromagnetic sources.
- Avoid servicing the unit during electrical storms.
- Do not touch non-insulated wires.

Internal Settings

The following procedure describes how to change the internal settings. If the intercom will be used as a *Listen/Talk unit* or as a *Master unit* in a *balanced line system*, then no changes to the internal PCBA's jumper or switch settings are required.

⚠ WARNING ⚠

Disconnect power to unit before opening to avoid possible damage to equipment or personal injury.

1. Disconnect power to the unit.
2. Loosen and remove the six screws securing the front cover.
3. Lift out the front panel assembly and tilt to the left. Use caution to ensure that no unnecessary strain is placed on the attached wiring harnesses.
4. If configuring the unit as a slave, slide the PCBA's mode switch (SW3) to the SLAVE position. See Figure 2.
5. If operating in an unbalanced cable system, reposition the PCBA's jumper P5/J5 from the BAL position to the UNBAL position. See Figure 2.
6. Reinsert the front panel assembly into the rear housing. Ensure that no wires are between the front panel's gasket and the housing's sealing surface that could be pinched.
7. Reinsert the six screws into the front cover and tighten securely.
8. Reapply the unit power and check for proper operation.

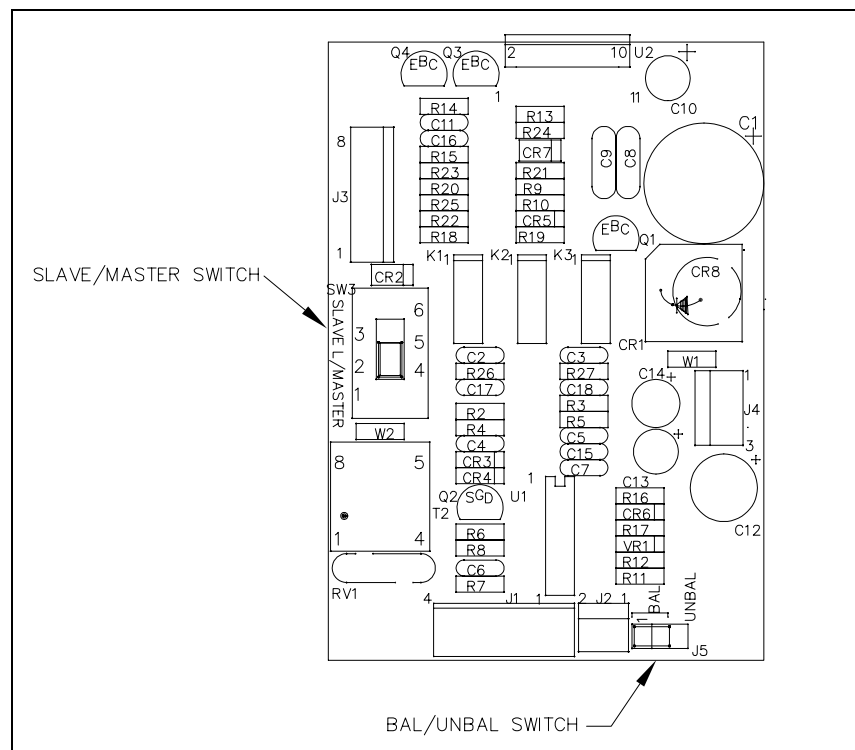

Figure 2. PCBA Outline Detail

Power Connection



WARNING

- Installation techniques must comply with all applicable electrical safety hazards/electrical codes.
- Remove local power before opening the unit or before performing any service.

Input Voltage	Model	Conductor 1		Conductor 2		Conductor 3		Conductor 4	
120 V ac via supplied 9.5-foot cord w/NEMA 5-15P plug	GC-AC1	Hot	Black	Neutral	White	Safety ground	Green	N/A	--
12-16 V dc (See note)	GC-DC1	(+)	Red	(-)	Black	Safety ground	Green	Not used (cut off)	White
230 V ac (See note)	GC-AC2	Hot	Red	Neutral (non-US)	White	Safety ground	Green	Not used (cut off)	Black

NOTES:

1. For Model GC-DC1 (12–16 V dc), the integral power cable is designed for connection to Class 2 circuits. For Model GC-AC2 (230 V ac) termination of the integral primary power cable must be made using a UL-approved junction box. If a customer-supplied interconnect plug is desired for interconnect, the plug must be UL-approved and rated for such purposes.
2. The audio/control wiring for all models is designed for connection to Class 2 circuits.

Mounting Instructions

The wall's mounting surface composition and hardware to be used (customer-supplied) **must be suitable** to withstand the unit's weight to prevent damage and/or personal injury.

If the unit is mounted to building structure, GTC Part No. 12704-001 Mounting Bracket Kit should be used. Refer to Pub. 42003-134 that accompanies the kit for more information.

There are two 0.406-inch (10.4 mm) diameter holes located in the mounting flanges spaced 5.875 inches (149.3 mm) apart. See Figure 1. The suggested mounting height for all station enclosures is 54 inches (137 cm) from the floor to the centerline of the enclosure.

Connection Instructions

System Line Balance

Each system requires termination of the audio pair wires with the 1 k Ω /1-watt resistor assembly included with each unit. The line balance resistor assembly is made for easy installation into the customer-supplied junction box. *Only one line balance resistor assembly is needed per system.*

For cable runs that are approximately 0.75 mile (1.2 km) or longer, it is recommended that the resistor assembly be installed in a junction box that is close to the center of the system.

System Interconnect

Refer to the interconnection diagram that is appropriate to the type of system you are installing.

Reminder about balanced and unbalanced systems: If interconnecting to an unbalanced system, be sure to move the Intercom's internal jumper (P5/J5) to the UNBAL position. For example, GAI-Tronics RigCom products use an unbalanced system, therefore, the Intercom's internal jumper (P5/J5) must be moved to the UNBAL position.

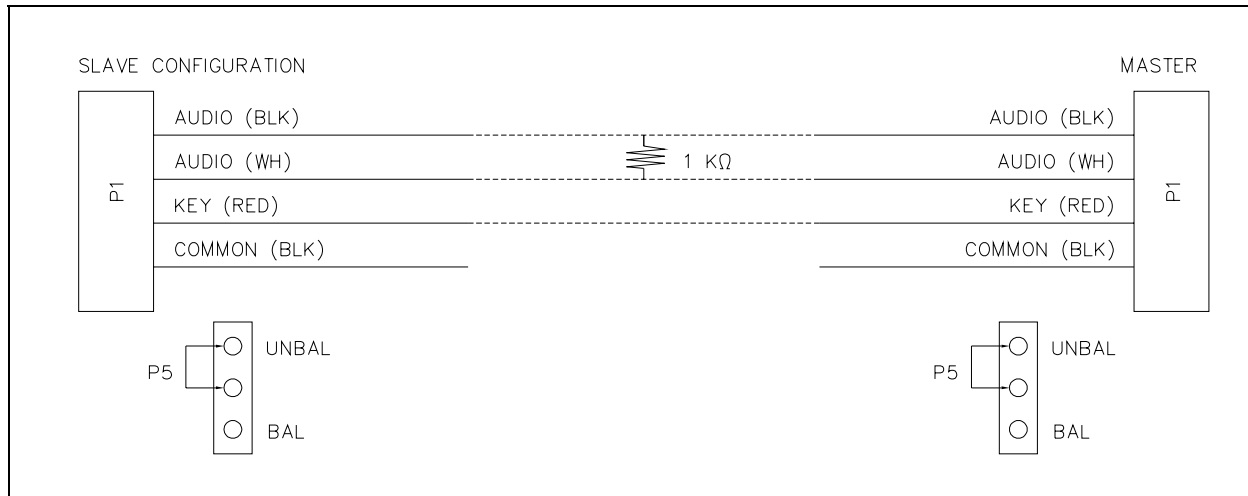

Figure 3. Master/Slave Unbalanced Configuration

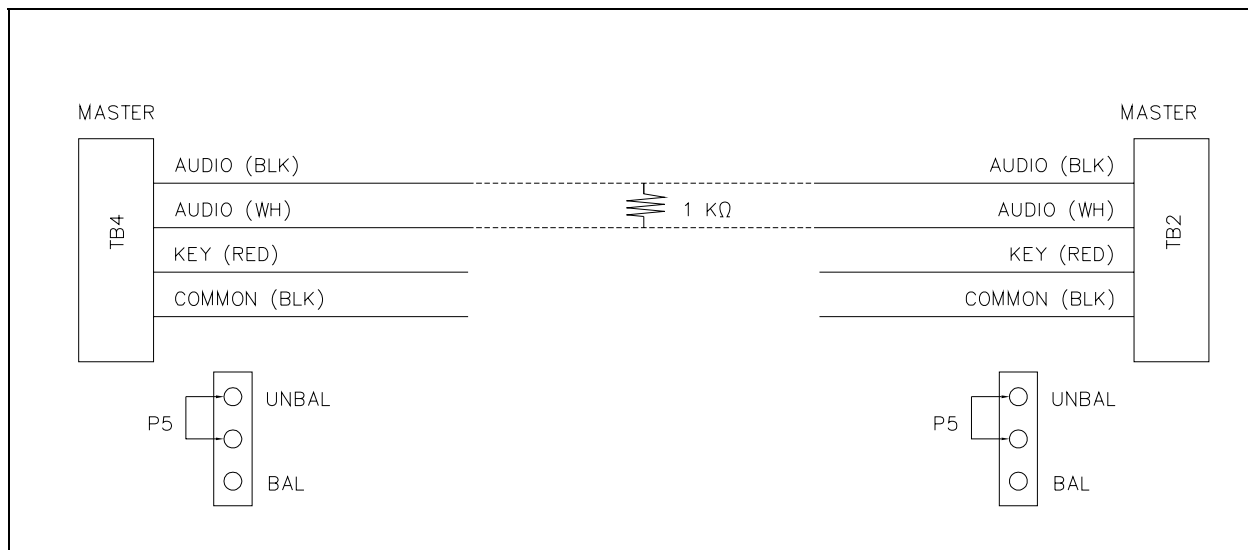

Figure 4. Unbalanced Common Line Configuration

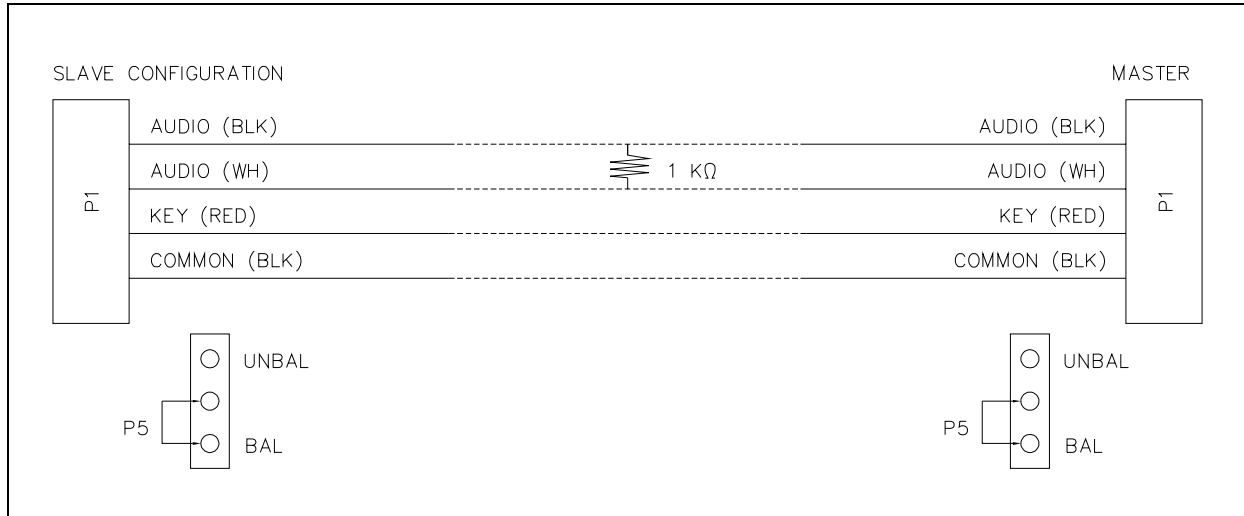

Figure 5. Master/Slave Balanced Configuration

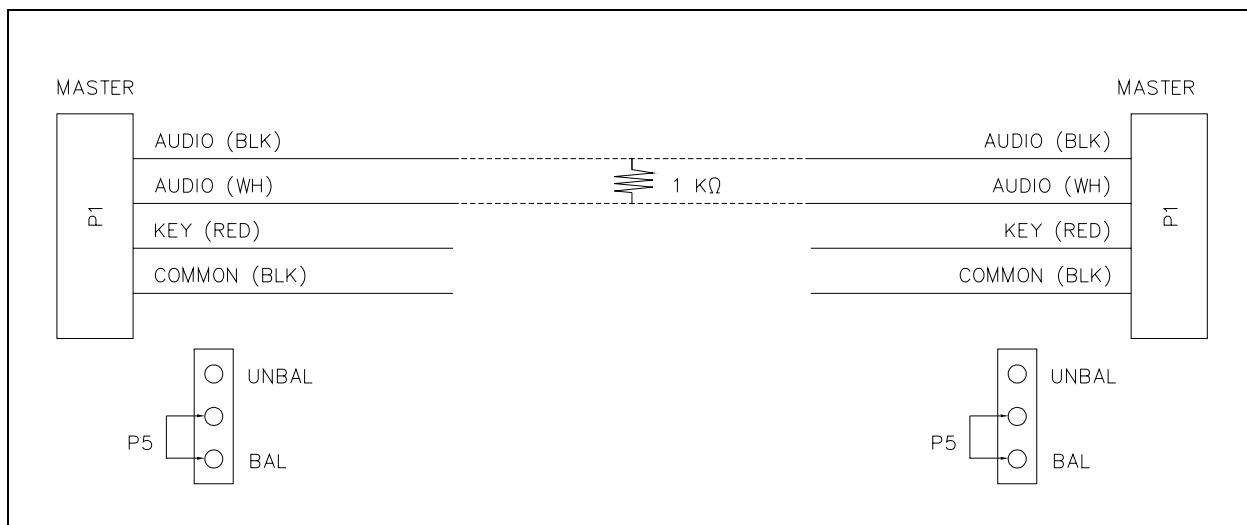

Figure 6. Balanced Common Line Configuration

Optional Footswitch Interface

Interconnection of a GAI-Tronics footswitch to a Listen/Talk or Master unit's control cable pair will allow hands-free operation of the unit's Listen/Talk functions. Refer to Figure 7 for more detail showing interconnection to system wiring. No internal connection to the unit is needed.

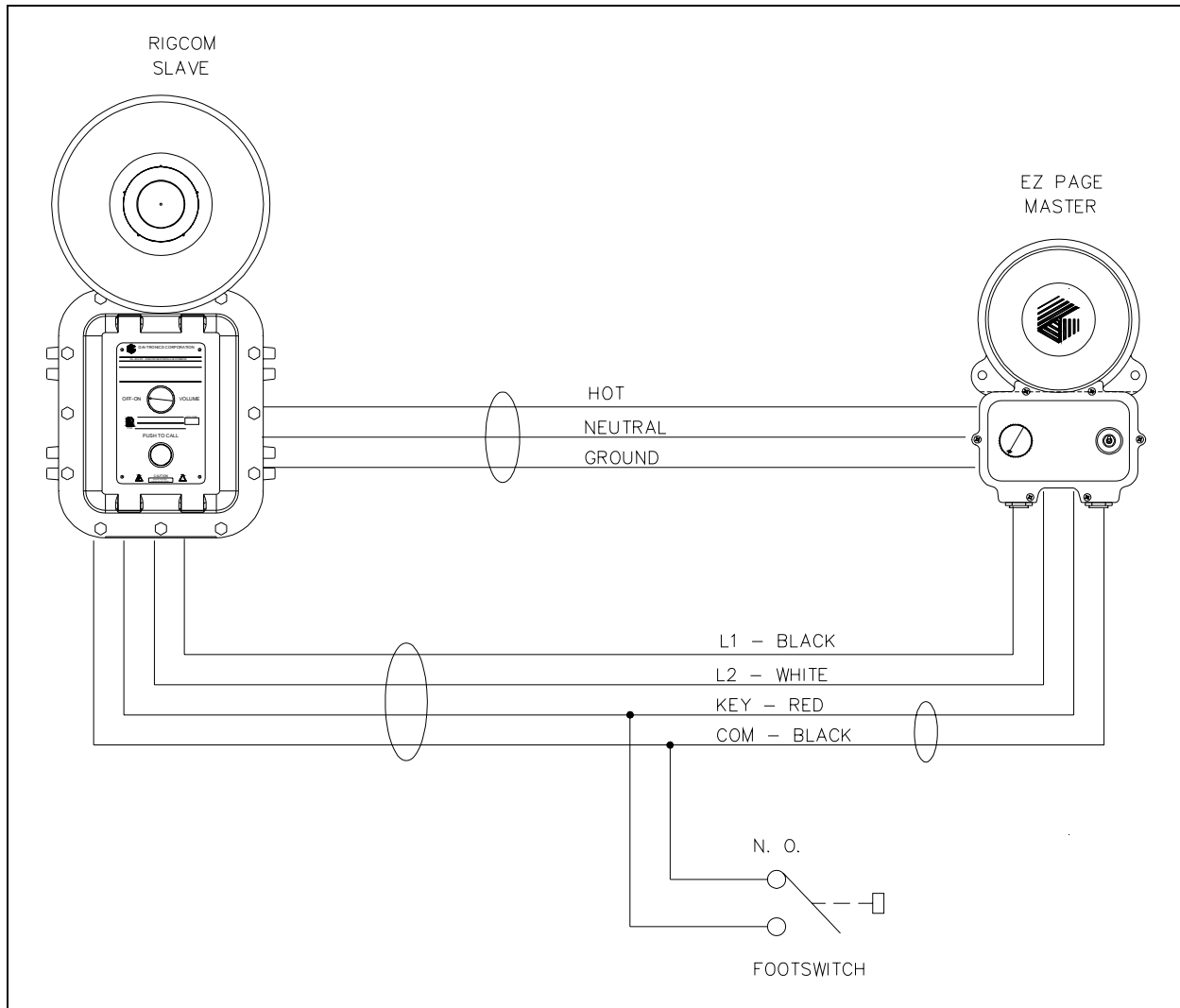

Figure 7. Footswitch Interconnection

Operation

Combination Speaker Volume/Mute On-Off Switch

Allows the user to adjust the received audio level. The control also allows the unit's speaker amplifier to be muted.

Listen/Talk Configured Units

Unit default: Listen mode

To make a page, hold down the Listen/Talk switch in the TALK position and talk into the speaker, which also acts as the microphone. Other units in the system, which are already in the listen mode, will broadcast the page from their speakers. Releasing the switch deactivates the microphone and returns the unit to the listen mode.

Master/Slave Configured Units

Master Unit

Unit default: Listen mode

Master unit is in the listen mode and will broadcast any audio generated from an associated Slave unit.

To make a page, hold down the Listen/Talk switch in the TALK position and talk into the speaker, which acts as the microphone. The Master unit's Listen/Talk switch performs the added function of switching the Slave unit's mode from talk to listen. The Slave unit will broadcast the received page from its speaker.

Releasing the Listen/Talk switch does the following:

- Returns the unit to the listen mode by switching the Master unit's microphone into its original speaker state
- Switches the Slave unit's mode from listen to talk

Slave Unit

Unit default: Talk mode

The Slave unit is in the talk mode until the Master station operator holds down the press-to-talk switch. The Slave unit operator does not have to hold down the press-to-talk switch—operation is hands-free. The Listen/Talk switch is not operable when the unit is configured as a Slave.

Maintenance

Internal Fuse Replacement

To reduce the risk of fire, replace fuses only with the same type and value as follows:

- For Model GC-AC1: 4/10 amp, slo-blo, 250 V, 3AG
- For Model GC-DC1: 2 amp, slo-blo, 250 V, 3AG
- For Model GC-AC2: 2/10 amp, slo-blo, 250 V, 3AG

Troubleshooting

Periodically check for frayed or cracked wiring, loose connections or signs of corrosion inside and outside of the unit.

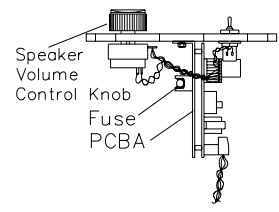
Problem	Possible Cause	Possible Solution
No audio is received at unit	<p>Unit's speaker is not turned on (muted)</p> <p>Local unit's speaker volume control is turned counterclockwise</p> <p>Internal fuse is blown</p>	<p>Check that local power is available and speaker volume switch is on.</p> <p>Adjust volume control to desired level.</p> <p>Replace fuse with exact voltage/fuse rating replacement.</p> 
Both paged audio and received audio is low	Short, or low resistance across audio pair in system cable	Correct system wiring.
Listen/Talk configured unit can't communicate to another Listen/Talk configured unit	<p>Possible system wiring error</p> <p>Connection of control pair wires to another Listen/Talk unit. <i>Note:</i> These wires should be left un-terminated and insulated.</p>	Correct system wiring.
Acoustic feedback when making a page	Units are positioned too close together or oriented toward each other	Reorient units away from each other or reduce speaker volume level.
Listen/Talk or Master unit is always in the talk mode	Internal mode switch is set to SLAVE	Reposition internal mode switch to L/MASTER.
	Possible low resistance between the red/black (control pair) wires within the unit or system cable.	Correct system wiring short.
Slave unit always in listen mode	Possible low resistance between the red/black (control pair) wires within the system cable connected to unit.	Correct system wiring short.
Master unit can not communicate to Slave unit, but Slave is communicating to Master unit	Possible open wire/connection of the control pair wires between units.	Correct connections and system wiring.
Excessive static/electromagnetic interference	System cable is routed too closely to high voltage, high electromagnetic sources.	Reroute system cable away from high voltage, high electromagnetic sources. Use shielded system cable.

General

External controls Speaker volume/on-off (mute), listen/talk switch

Internal primary fuse:

GC-AC1 4/10 amp, 250 V, slo-blo (.25 × 1.25 inch)

GC-DC1 2 amp, 250 V, slo-blo (.25 × 1.25 inch)

GC-AC2 2/10 amp, 250 V, slo-blo (.25 × 1.25 inch)

Integral cables:

Power: GC-AC1 ~9.5-foot, 3-conductor, No. 18 AWG, type SJTW with NEMA 5-15P plug

Power: GC-DC1, GC-AC2 ~9.5-foot, 4-conductor, 18 AWG, SJOW with wire ends

Audio/Control ~9.5-foot, 2 twisted pair cable, 18 AWG, PVC with wire ends

Enclosure Cast aluminum

Color Blue (RAL5017)

Temperature Range (Operating/Storage) -40° F to +158° F (-40° C to 70° C)

Dimensions 11.2 H × 6.97 W × 5.45 D (284.5 × 177 × 138.4 mm)

Recommended: Maximum number of Listen/Talk units per system 20

Maximum number of Slave units per Master unit 1

Shipping weight: GC-AC1 and GC-AC2 13 lbs. (5.9 kg)

Shipping weight: GC-DC1 12 lbs. (5.4 kg)

Unit weight: GC-AC1 and GC-AC2 11.1 lbs. (5.1 kg)

Unit weight: GC-DC1 10 lbs. (4.5 kg)

Replacement Parts

Model Number	Description
12604-009	GC-AC1 120 V AC Fuse Kit (10 fuses each)
12604-010	GC-DC1 DC Fuse Kit (10 fuses each)
12604-011	GC-AC2 230V AC Fuse Kit (10 fuses each)
12702-001	AC Board Replacement Kit
12702-002	DC Board Replacement Kit
12504-009	Front Panel Switch Kit
12703-001	Speaker Driver Kit

Appendix A

Interfacing an EZ Page Station to MS39xx Series RigCom Stations

The EZ Page station is designed to operate with the MS39xx Series RigCom Stations.

The MS39xx Series uses an unbalanced system for communication and uses the negative of the audio pair as the ground reference for the control signal. The EZ Page has the ability to operate unbalanced or balanced. In the balanced system, the audio pair is not ground referenced and the control signal requires a ground signal with it.

For interoperability between the EZ Page and the MS39xx Series, configure the EZ Page for an unbalanced system by placing the jumper for P5 in the UNBAL position. No changes are required to the MS39xx Series. For Master/Slave operation, connect AUDIO- to AUDIO (WH), AUDIO+ to AUDIO (BLK) and EXT CONT+ to KEY. For common line only the audio wires need connection.

The following are wiring diagrams for the different configurations of a system.

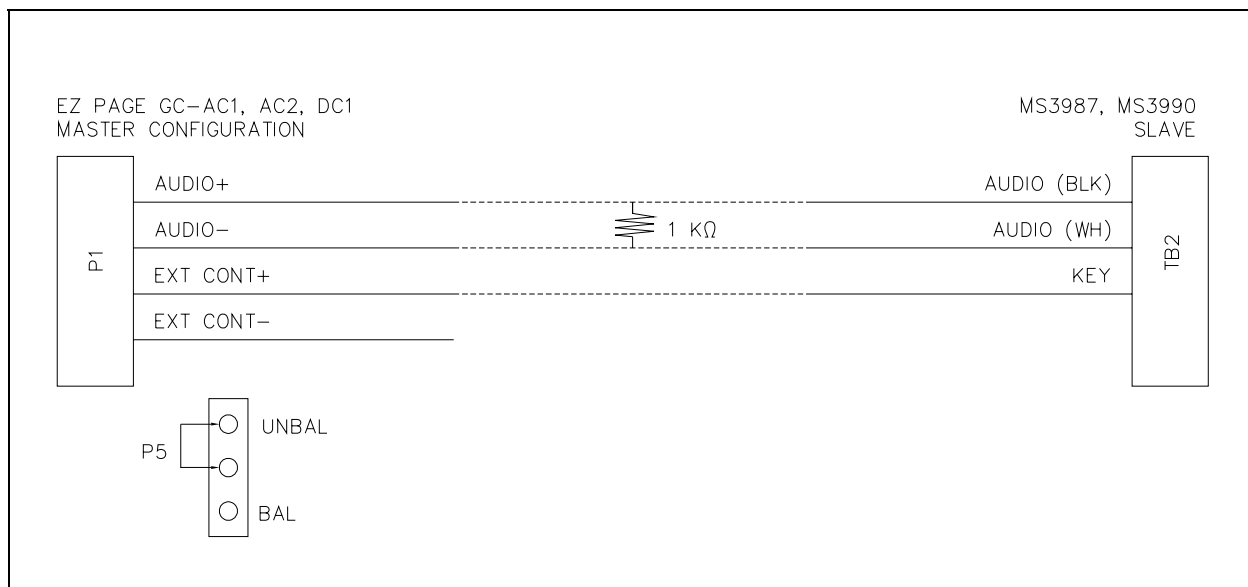

Figure 8. Master/Slave Configuration with EZ Page as Master

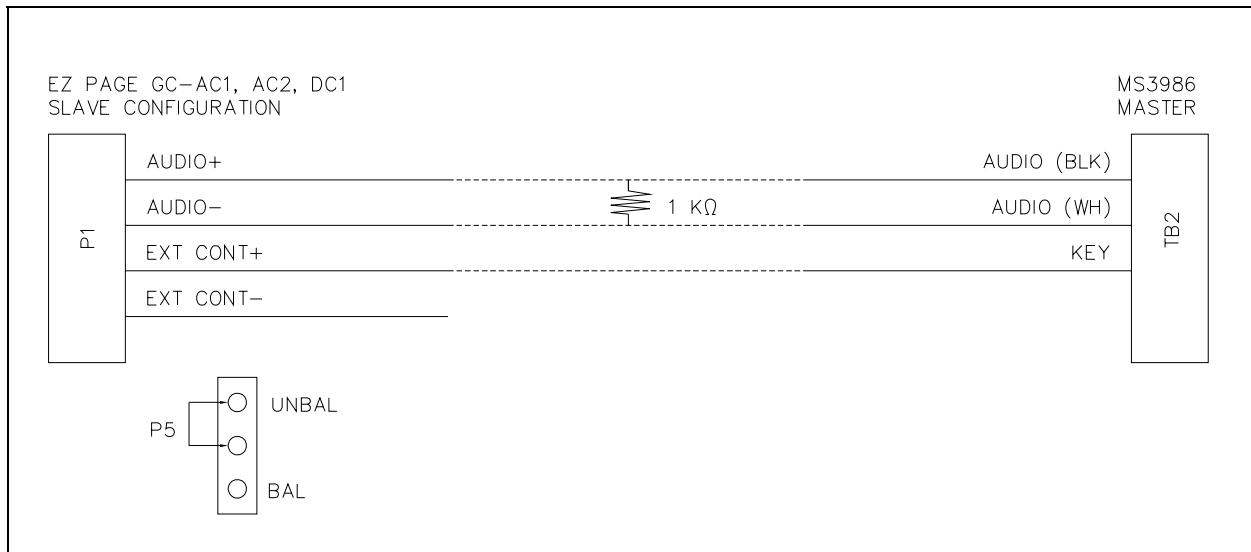

Figure 9. Master/Slave Configuration with EZ Page as Slave

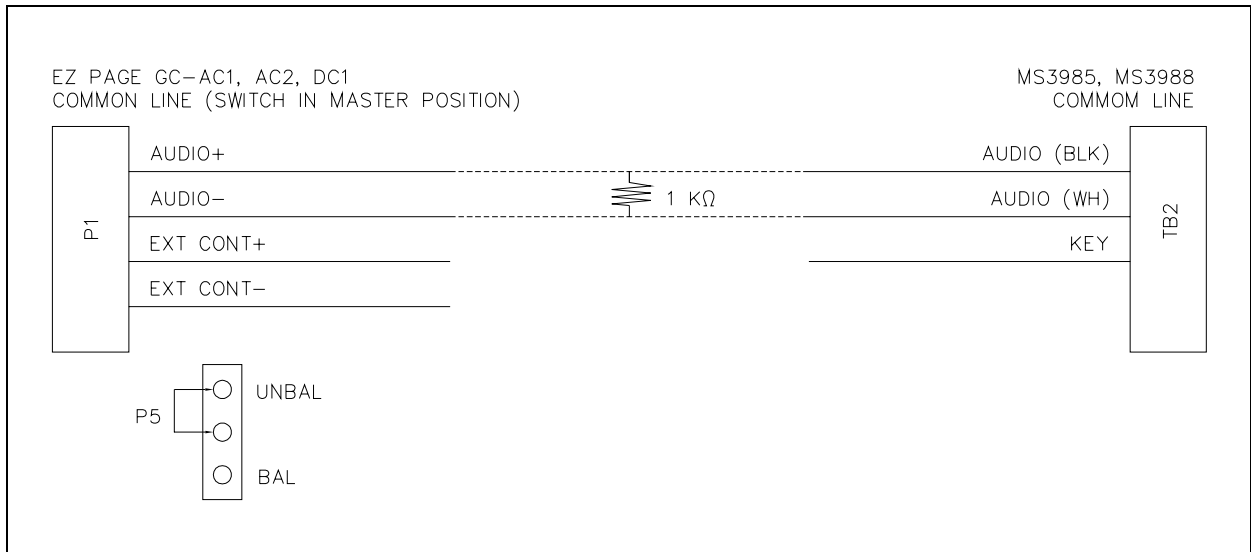

Figure 10. Common Line Configuration

Appendix B

Interfacing EZ Page Stations to Model 400-001 RigCom Stations

The EZ Page and Model 400-001 stations are designed to operate either in balanced or unbalanced systems. An unbalanced system for communication uses the negative of the audio pair as the ground reference for the control signal. In the balanced system, the audio pair is not ground referenced and the control signal requires a ground signal.

For interoperability between the Model 400-001 and the EZ Page Series, configure the 400-001 and the EZ Page identically, balanced or unbalanced, by the location of P5 on the EZ Page and P3 on the Model 400-001.

The following wiring diagrams are for the different configurations for RigCom/EZ Page systems.

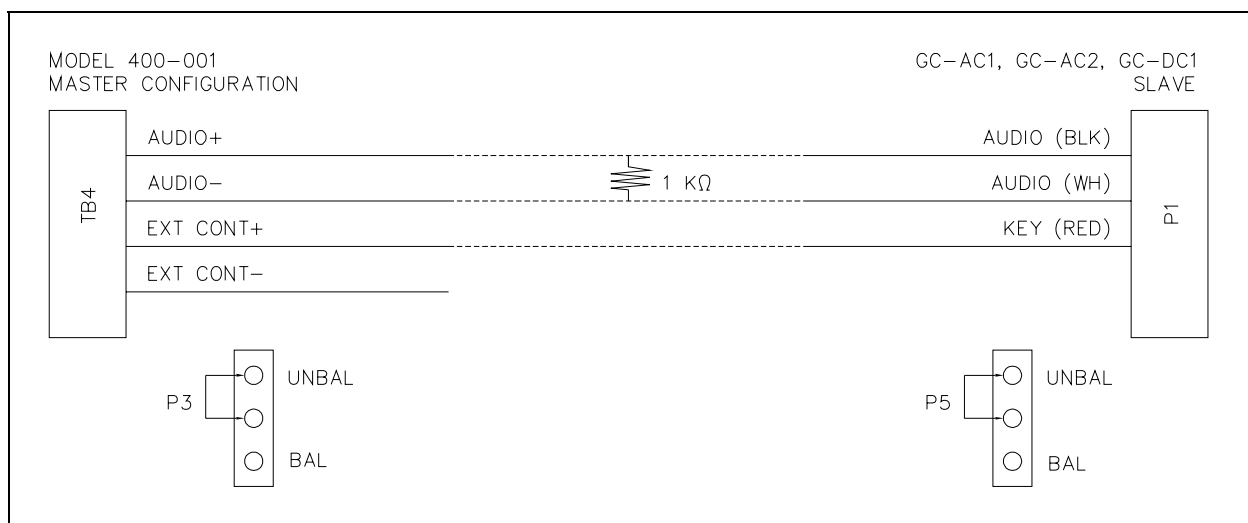

Figure 11. Master/Slave Unbalanced Configuration with Model 400-001 Master

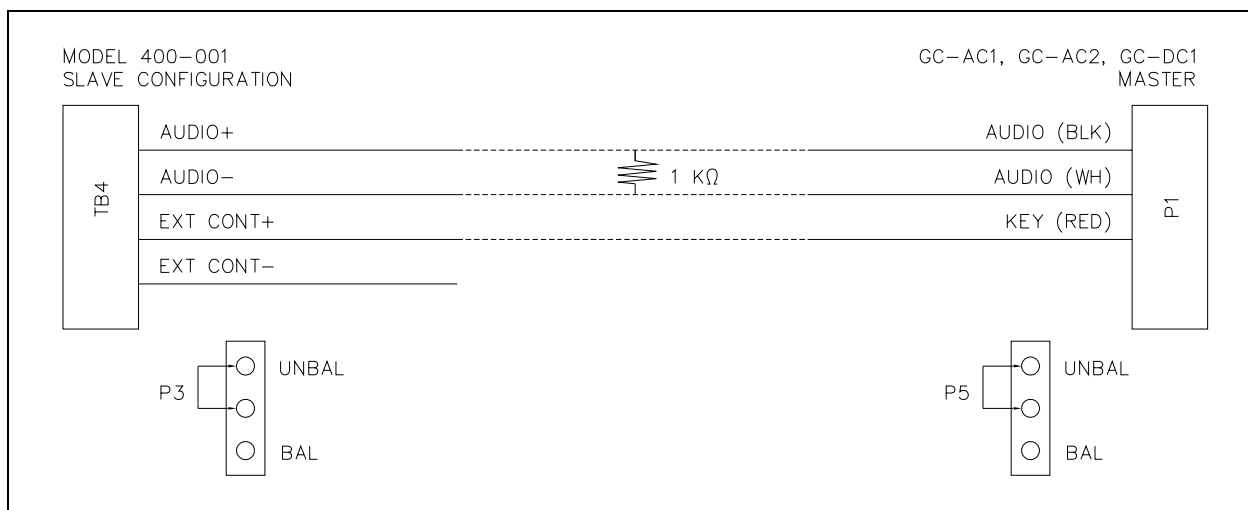

Figure 12. Master/Slave Unbalanced Configuration with Model 400-001 as Slave

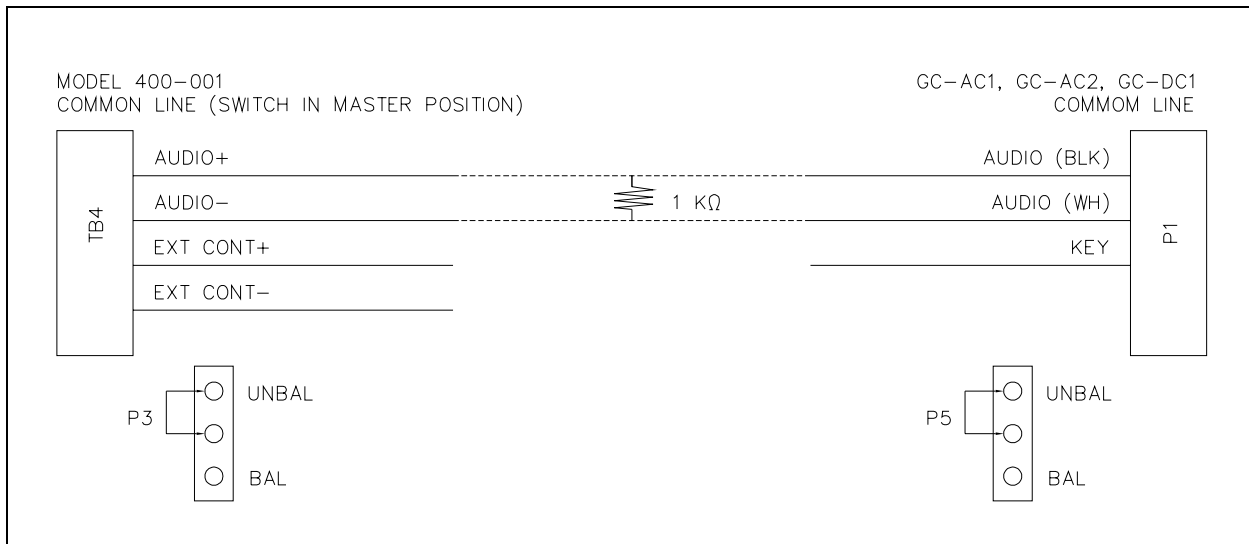

Figure 13. Unbalanced Common Line Configuration

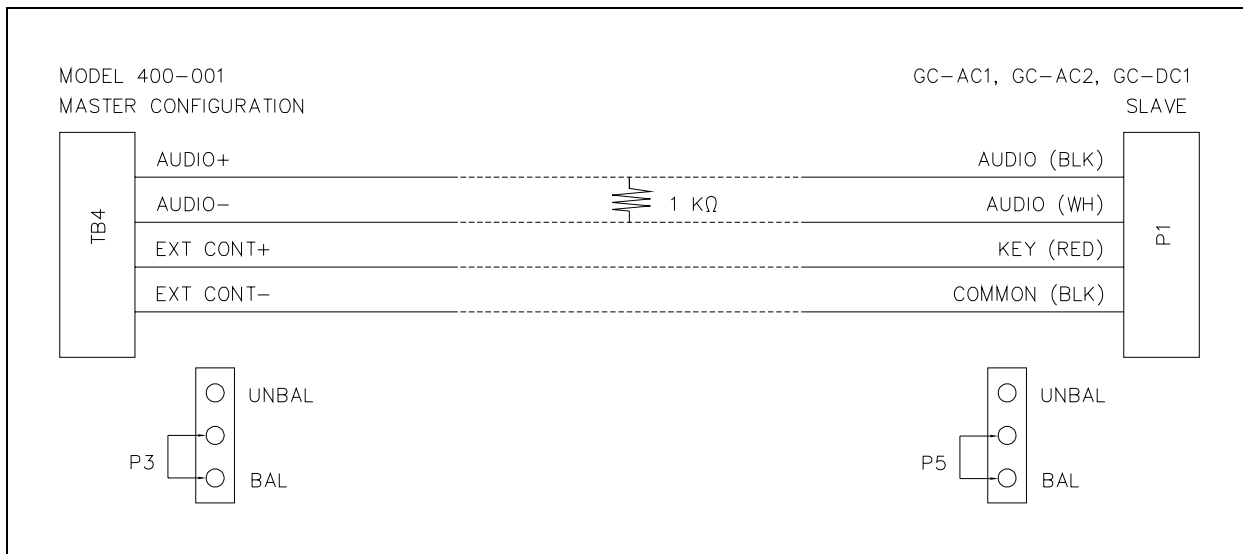

Figure 14. Master/Slave Balanced Configuration with Model 400-001 as Master

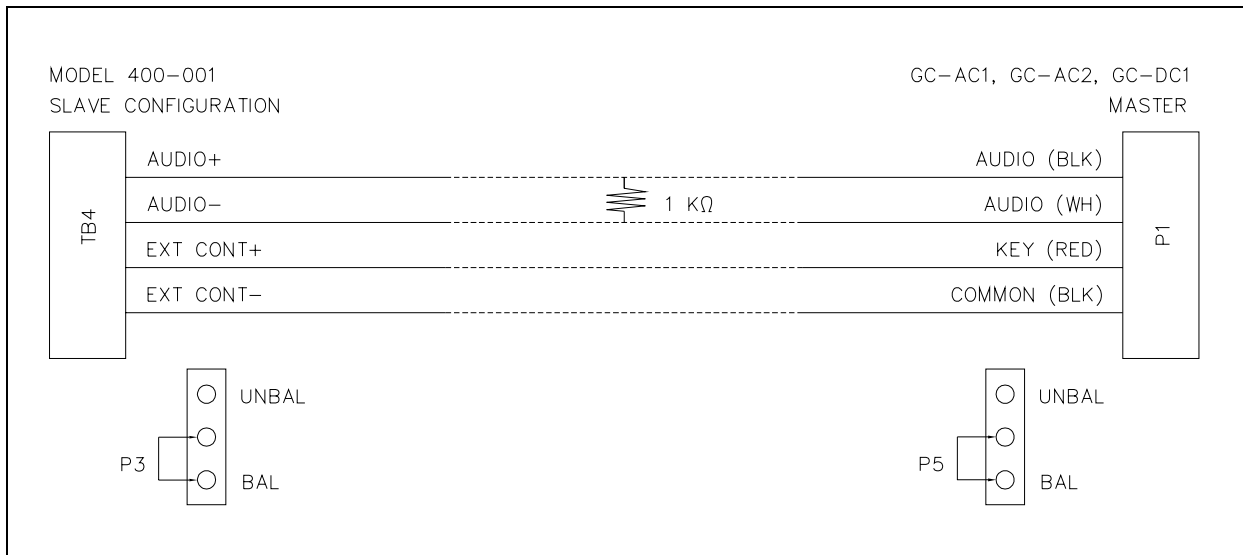

Figure 15. Master/Slave Balanced Configuration with Model 400-001 as Slave

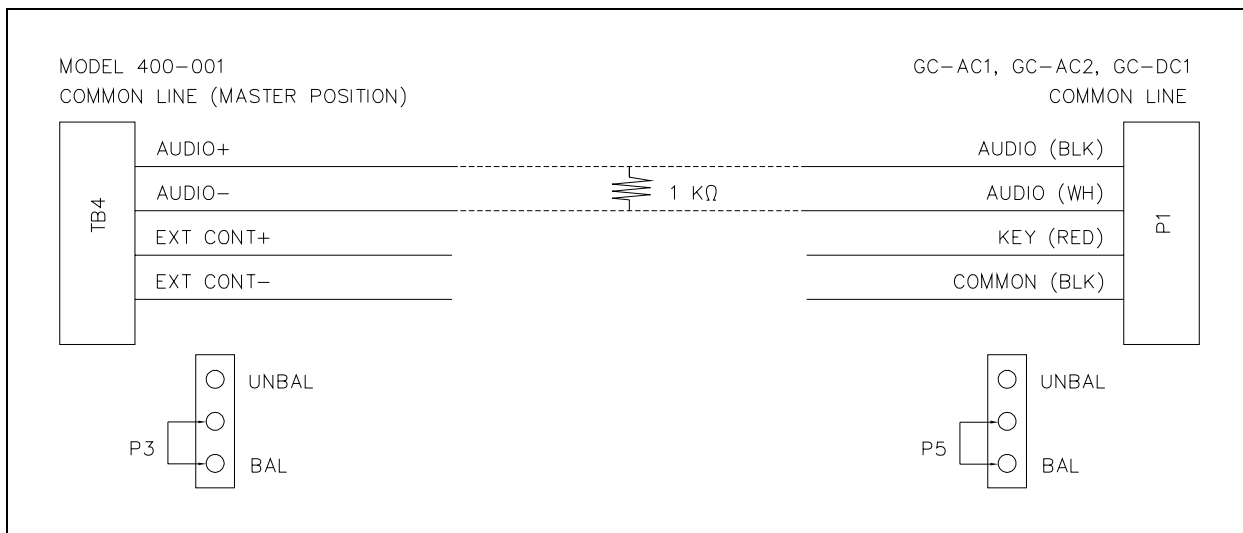

Figure 16. Balanced Common Line Configuration

Warranty

Equipment. GAI-Tronics warrants for a period of one (1) year from the date of shipment, that any GAI-Tronics equipment supplied hereunder shall be free of defects in material and workmanship, shall comply with the then-current product specifications and product literature, and if applicable, shall be fit for the purpose specified in the agreed-upon quotation or proposal document. If (a) Seller's goods prove to be defective in workmanship and/or material under normal and proper usage, or unfit for the purpose specified and agreed upon, and (b) Buyer's claim is made within the warranty period set forth above, Buyer may return such goods to GAI-Tronics' nearest depot repair facility, freight prepaid, at which time they will be repaired or replaced, at Seller's option, without charge to Buyer. Repair or replacement shall be Buyer's sole and exclusive remedy. The warranty period on any repaired or replacement equipment shall be the greater of the ninety (90) day repair warranty or one (1) year from the date the original equipment was shipped. In no event shall GAI-Tronics warranty obligations with respect to equipment exceed 100% of the total cost of the equipment supplied hereunder. Buyer may also be entitled to the manufacturer's warranty on any third-party goods supplied by GAI-Tronics hereunder. The applicability of any such third-party warranty will be determined by GAI-Tronics.

Services. Any services GAI-Tronics provides hereunder, whether directly or through subcontractors, shall be performed in accordance with the standard of care with which such services are normally provided in the industry. If the services fail to meet the applicable industry standard, GAI-Tronics will re-perform such services at no cost to buyer to correct said deficiency to Company's satisfaction provided any and all issues are identified prior to the demobilization of the Contractor's personnel from the work site. Re-performance of services shall be Buyer's sole and exclusive remedy, and in no event shall GAI-Tronics warranty obligations with respect to services exceed 100% of the total cost of the services provided hereunder.

Warranty Periods. Every claim by Buyer alleging a defect in the goods and/or services provided hereunder shall be deemed waived unless such claim is made in writing within the applicable warranty periods as set forth above. Provided, however, that if the defect complained of is latent and not discoverable within the above warranty periods, every claim arising on account of such latent defect shall be deemed waived unless it is made in writing within a reasonable time after such latent defect is or should have been discovered by Buyer.

Limitations / Exclusions. The warranties herein shall not apply to, and GAI-Tronics shall not be responsible for, any damage to the goods or failure of the services supplied hereunder, to the extent caused by Buyer's neglect, failure to follow operational and maintenance procedures provided with the equipment, or the use of technicians not specifically authorized by GAI-Tronics to maintain or service the equipment. **THE WARRANTIES AND REMEDIES CONTAINED HEREIN ARE IN LIEU OF AND EXCLUDE ALL OTHER WARRANTIES AND REMEDIES, WHETHER EXPRESS OR IMPLIED BY OPERATION OF LAW OR OTHERWISE, INCLUDING ANY WARRANTIES OF MERCHANTABILITY OR FITNESS FOR A PARTICULAR PURPOSE.**

Return Policy

If the equipment requires service, contact your Regional Service Center for a return authorization number (RA#). Equipment should be shipped prepaid to GAI-Tronics with a return authorization number and a purchase order number. If the equipment is under warranty, repairs or a replacement will be made in accordance with the warranty policy set forth above. Please include a written explanation of all defects to assist our technicians in their troubleshooting efforts.

Call 800-492-1212 (inside the USA) or 610-777-1374 (outside the USA) for help identifying the Regional Service Center closest to you.